

OBSOLETE
ECO 120125-7

1 Watt SLC Single Series DC/DC Converters

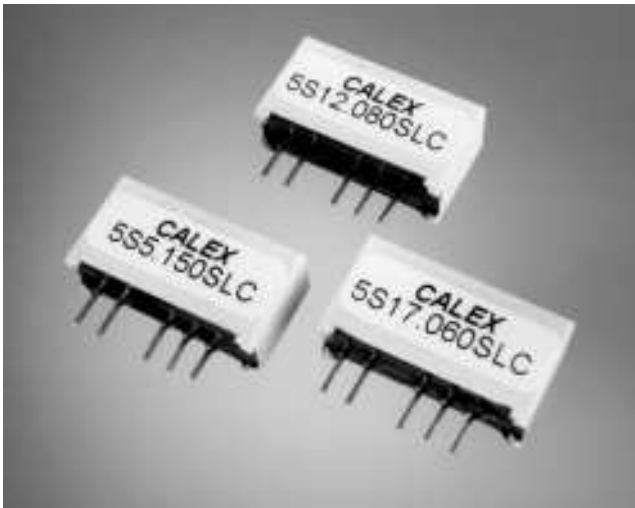

Features

- Low Cost
- Operating Range of 4.5 to 5.5 Volts
- Semi-Regulated 1 Watt Outputs
 - 5, 12, 15 and 6, 7, 14, 17, 24 Volt Outputs
- Simple Four Terminal Operation
- Small SLC package, Fits in 0.19 sq.in. of PCB Area
- Low Noise Operation
- 5 Year Warranty
- RoHS Compliant

Description

The CALEX SLC is specifically designed to provide nonstandard output voltages and isolation for 5 volt digital systems. The series provides semi-regulated outputs of 5, 6, 12, 15, and 24 volts for directly driving your circuits or 7, 14 and 17 volt outputs for driving three terminal regulators.

The high efficiency operation of typically 74% for a 12 volt output means efficient use of your system power.

Easy four terminal operation makes using the converter a snap. Just plug it in and you are ready to solve those nasty analog problems that arise when only 5 volt digital power is available in your system.

RoHS Compliant:

RoHS Compliance means conformity to EU Directive 2002/95/EC of 27 January 2003, on the restriction of the use of certain hazardous substances in electrical and electronic equipment, lead, cadmium, mercury, hexavalent chromium, polybrominated biphenyls, and polybrominated diphenyl ethers are not present in quantities exceeding the following maximum concentrations in any homogeneous material, except for applicable exemptions.

0.1% (by weight of homogeneous material) lead, mercury, hexavalent chromium, polybrominated biphenyls, polybrominated diphenyl ethers, or 0.01% (by weight of homogeneous material) cadmium. The RoHS marking is as follows:



Selection Chart					
Model	Input Range VDC		Output		
	Min	Max	VDC	mA	Power W
5S5.150SLC	4.5	5.5	5.0	150	¾
5S6.145SLC	4.5	5.5	6.0	145	1
5S7.140SLC	4.5	5.5	7.0	140	1
5S12.080SLC	4.5	5.5	12.0	80	1
5S14.070SLC	4.5	5.5	14.0	70	1
5S15.065SLC	4.5	5.5	15.0	65	1
5S17.060SLC	4.5	5.5	17.0	60	1
5S24.040SLC	4.5	5.5	24.0	40	1

1 Watt SLC Series Block Diagram

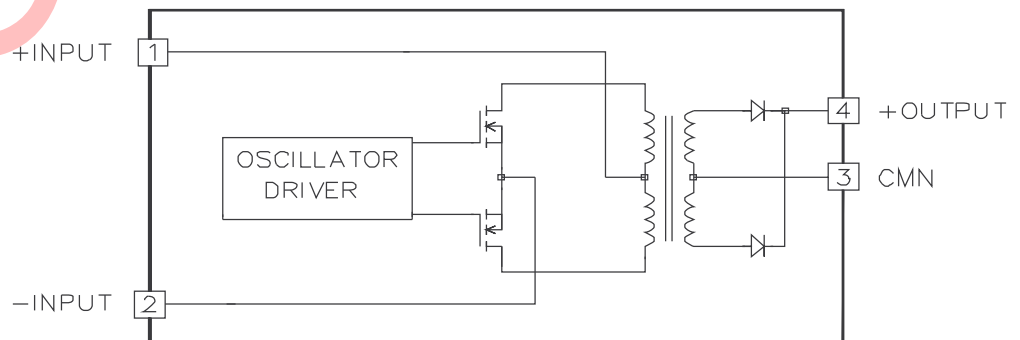

1 Watt SLC Single Series DC/DC Converters

Input Parameters*										
Model		5S5.150SLC	5S6.145SLC	5S7.140SLC	5S12.080SLC	5S14.070SLC	5S15.065SLC	5S17.060SLC	5S24.040SLC	Units
Voltage Range	MIN	4.5								VDC
	MAX	5.5								
Reflected Ripple (1)	TYP	50	65	65						mA P-P
Input Current										
	Full Load	TYP	205	238	258	249	255	253	265	249
No Load	TYP	25	25	25	25	25	25	30	30	
Efficiency	TYP	73	73	76	77	77	77	77	77	%
Switching Frequency	TYP	105								kHz

Output Parameters*										
Model		5S5.150SLC	5S6.145SLC	5S7.140SLC	5S12.080SLC	5S14.070SLC	5S15.065SLC	5S17.060SLC	5S24.040SLC	Units
Output Voltage		5	6	7	12	14	15	17	24	VDC
Output Voltage Accuracy (2)	MIN	4.75	5.675	6.65	11.40	13.30	14.25	16.15	22.8	VDC
	TYP	5.00	6.000	7.00	12.00	14.00	15.00	17.00	24.0	
	MAX	5.25	6.325	7.35	12.60	14.70	15.75	17.85	25.2	
Output Voltage, No Load	TYP	7	8	9	15	17	18	20	26	VDC
Rated Load Range	MIN	0	0	0	0	0	0	0	0	mA
	MAX	150	145	140	80	70	65	60	40	
Load Regulation (3)										%
	75% - 20% Load	TYP	+8							
75% - 100% Load	TYP	-5								
Line Regulation (4)	TYP	1.2								% / %
Noise, Peak - Peak (1)	TYP	65			40					mV P-P
Temperature Coefficient	TYP	400								ppm/°C
Short Circuit Protection to Common (5)		Momentary								

NOTES

* All parameters measured at Tc = 25°C, 5.00V input voltage, full rated load and a 10µF solid tantalum capacitor connected across the input and output pins, unless otherwise noted. Refer to the CALEX Application Notes for the definition of terms, measurement and other information.

(1) Noise is measured per CALEX Application Notes. Measurement bandwidth is 20 MHz. Input Reflected Ripple and output noise are measured with a 10µF tantalum capacitor connected across the input and output pins.

- (2) Output Voltage Accuracy measured at 75% of maximum Rated Load.
- (3) Load Regulations measured relative to 75% of maximum Rated Load Current. See Output Voltage vs. Output Load Curves.
- (4) Line Regulation is for a 1.0% change in Input Voltage.
- (5) Use input fuse for protection. See Applying the Input.
- (6) The case Thermal Impedance is specified as the case temperature rise over ambient per package watt dissipated.
- (7) Specifications subject to change without notice.
- (8) Water Washability - Calex DC/DC converters are designed to withstand most solder/wash processes. Careful attention should be used when assessing the applicability in your specific manufacturing process. Converters are not hermetically sealed.

General Information

The 1 Watt SLC series provides isolated semi-regulated outputs of 5, 6, 7, 12, 14, 15, 17, and 24 VDC. The high efficiency low noise push-pull design operates at 165 kHz which reduces to a minimum your external filter requirements. The converter is packaged in a non-conductive plastic case and can be water washed after assembled to your main PC board.

Applying The Input

Figure 1 shows the recommended input connections for the 1 Watt Output SLC series. This series is only protected for momentary output short circuits to common so a fast acting fuse is recommended to protect the input circuit. It should not be omitted as it serves to prevent unlimited current from flowing in the case of an overcurrent at the load.

C1 may not be required when the power source is less than 2" from the unit. The source impedance should be less than

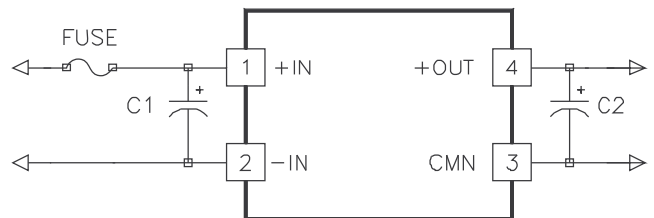

C1 = 10µF, SEE APPLYING THE INPUT,
C2 = 10µF MINIMUM, SEE APPLYING THE OUTPUT.

Figure 1. 1 Watt SLC Series Typical Application

0.5 ohm over the frequency range of DC to 165 kHz. A 10µF solid tantalum capacitor will satisfy the requirements for C1, and should be within 2" of the converter.

1 Watt SLC Single Series DC/DC Converters

General Specifications*			
All Models			Units
Isolation			
Isolation Voltage Input to Output 10 μ A	MIN	750	VDC
Input to Output Capacitance	TYP	25	pF
Environmental			
Case Operating Range			
No Derating	MIN MAX	-25 +85	$^{\circ}$ C
Storage Range	MIN MAX	-40 100	$^{\circ}$ C
Thermal Impedance (θ)	TYP	58	$^{\circ}$ C/Watt
Unit Weight	TYP	0.1	oz
Case Material	Non Conductive Plastic		

Very Low Noise Input Circuit

Figure 2 shows a very low noise input circuit that may be used with the converters. This circuit will reduce the input reflected ripple current to less than 5 mA peak to peak. L1 should be sized to handle the maximum DC current of your application. C1 must be used if L1 is required in the circuit.

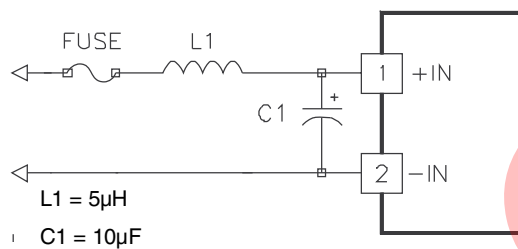

Figure 2.

This circuit will reduce the input reflected ripple current to less than 5 mA peak to peak. See the discussion in the text for selecting C1 and L1.

Applying The Output

Figure 1 shows the typical output connection for the converter. C2 is required to filter the output. It must be 10 μ F minimum and can be made up of from the bypass capacitors already used in your application. Increasing C2 will lower the output noise.

Operation With Light Loads

This converter uses a semi-regulated design. The output voltage will vary as the load is changed, increasing as the load is decreased. See the Output Voltage vs. Output Load curve.

Operation With Changing Input Voltage

The output will change proportionally to a change in the input voltage. The typical output voltage change is 1.2% per % change in input voltage.

Low Noise Output Circuit

The circuit shown in Figure 3 can be used to reduce the output noise to below 4 mV p-p over a 20 MHz bandwidth. Size

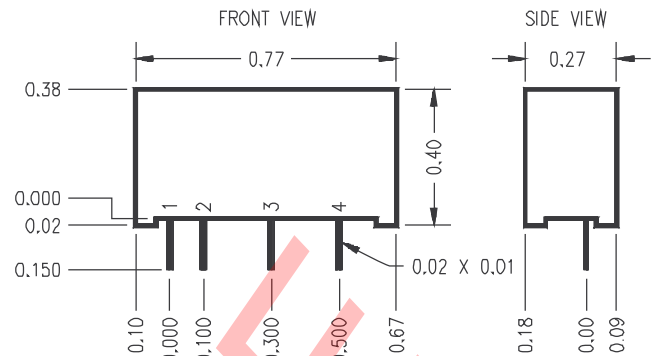

Mechanical tolerances unless otherwise noted:

X.XX dimensions: ± 0.020 inches

X.XXX dimensions: ± 0.010 inches

Pin	Function
1	+INPUT
2	-INPUT
3	CMN
4	+OUTPUT

inductor L2 appropriately for the maximum expected load current. All the ground connections must be as short as possible back to the CMN pin. The filter should be placed as close as possible to the converter, even if your load is at some distance.

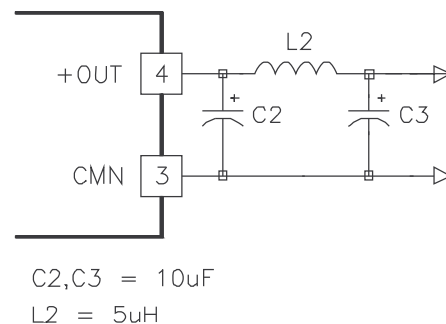

Figure 3.

This circuit can reduce the output noise to below 4mV P-P over a 20 MHz bw. Size L2 for the maximum expected load current. Place as close as possible to the converter.

Negative Outputs

A negative output voltage is obtained by connecting the +Output pin to the low side of the load, and taking the negative output from the CMN pin of the converter.

Grounding

The input and output sections are fully floating and isolated from each other. They may be operated fully floating or with a common connection between the input and output.

1 Watt SLC Single Series DC/DC Converters

Temperature Derating

The 1 Watt Output SLC series can be operated up to a +85°C case temperature. Case temperature can be roughly calculated from ambient by knowing that the case temperature rise is approximately 58°C per package watt dissipated.

For example: If a 5S12.080SLC is delivering 0.9 watts at 5V input, at what ambient could it expect to run with no additional cooling such as moving air?

Efficiency is approximately 73% which leads to an input power of 1.23 watts. The internal power loss is $1.23 - .9 = 0.33$ watts. The case temperature rise will be $0.33W \times 58^\circ C/W = 19.1^\circ C$. This number is subtracted from the maximum

case temperature rating of 85°C to get 65.9°C, which is the maximum ambient operating temperature.

This example calculation is for an application with no extra air flow for cooling. Extra cooling air will greatly effect the maximum ambient temperature. Exact internal power loss depends upon the efficiency, input voltage, and load in the application.

The above example is a rough approximation to the maximum ambient temperature. Because of the difficulty of defining ambient temperature, these calculations should be verified by actual measurement before committing to a production design.

Typical Performance: (Tc=25°C)

