



OPERATION M A N U A L

Model

LOAD CELL SUMMING TRANSMITTER

48000

MODEL 4800

LOAD CELL SUMMING TRANSMITTER

OPERATION MANUAL

I. GENERAL DESCRIPTION

1. Features	2
2. Application	2
3. Brief Description	3
4. Operation	3
5. Specifications	4
6. Instrument layout	5

II. INSTALLATION

1. Item check list	6
2. Mounting	6
3. Electrical Connections	6

III. SETUP

1. Setting the Excitation Voltage	8
2. Single Load Cell System Adjustment	8
3. Multiple Load Cells System Adjustment	9
4. Troubleshooting	11

IV. OPTIONS

1. Enclosures	12
2. Dual Set Point Relays (Installation and Setup)	12

I. GENERAL DESCRIPTION

1. Features

- ◆ Summing of up to 4 load cells
- ◆ Complete strain gage bridge signal conditioner
- ◆ High gain, low drift, low temperature coefficient precision amplifiers, with low input current (10 pA typical)
- ◆ Wide input range from 5 mV to 50 mV full scale
- ◆ Very stable bridge balance with 80% tare offset capability
- ◆ 4-20 mA or 0-20 mA output
Capable of driving 1000 ohm loop
- ◆ 2 to 10 V or 0 to 10 V output
- ◆ Excitation supply capable of driving four load cells
 - Typical 0.001% temperature coefficient
 - Wide adjustment voltage range
 - Long distance remote sense capability
 - Very good line and load regulation
- ◆ Both AC & DC power capability
Surge voltage suppression
- ◆ Input, output and power three way isolation
- ◆ NEMA 4 enclosure for use in rugged environments

2. Application

- ◆ Precision weighing with load cells
- ◆ Process control add-on loops
- ◆ Can be used with all types of low output sensors

3. Brief Description

The Model 4800 is an AC or DC powered Summing Transmitter for up to four load cells with output options of 0 to 20 mA, and 0 to 10 V or 4 to 20 mA, and 2 to 10 V. All input/output options are included on one board so there is no need to specify input/output parameters with the 4800.

The 4800 has a built in excitation supply capable of delivering up to 120 mA from 5 to 10 V, more than enough current to drive four 350 ohm load cells.

The 4800 offers three way isolation, input to output and power, eliminating unwanted ground loop problems. Overall accuracy over the normal room temperature range is excellent at $<\pm 0.1\%$ of full scale. The high gain, very low drift and very low temperature coefficient of the 4800 amplifier allows full scale live load signals as low as 5 mV to be amplified to 20 mA or 10 V.

Designed with large and very stable tare offset requirements in mind, the 4800 can tare off up to 80 % of the output of a 3 mV/V load cell (at 10 V excitation).

If high/low setpoint alarms/controls are desired, the 4800 board is laid out to accept Opto-22 output relays. Potentiometers are accessible to adjust the high and low trip points.

4. Operation

The 4800 accepts DC mV signals from up to four load cells which are summed together, then amplified, isolated and filtered. The 4800 features a very stable on-board excitation supply and precision amplifier. They are designed for very low drift and a small temperature coefficient, critical for high accuracy. The full scale output is either 20 mA or a 10 V signal for industrial control. A wide AC and DC power voltage range is allowed for convenience.

5. Specifications

NOTE: Unless otherwise noted, specifications apply after half hour warm up at 23°C ±2 °C ambient. Temperature Coefficients apply between 0°C and 55°C ambient.

ACCURACY

10 TO 35°C, at 10 V Excitation	Less than ±0.1%
Total Temperature Coefficient (TC)	0.0025%/°C typ

ISOLATION

AC or DC Powered - Three Way Isolated	
AC to Input and Output	750 VAC
DC to Input to Output	300 VDC 500 pF

AMPLIFIER SECTION

Gain	
Input Range	5 mV to 50 mV Full Scale
Linearity	±0.01% of Full Scale
TC	0.0015%/°C typ
Input Noise - 0.1 Hz to 10 Hz	2µV PP
Tare Adjustment Range	-3 mV to +6.5 mV
(Bridge Offset)	+6.5 mV to +16 mV
(Equals 80% F.S. of 3 mV/V cell at 10 V	+16 mV to +25 mV
Temperature Coefficient	0.0015%/°C typ
Common Mode Rejection	100 dB Min
Common Mode Input Voltage	+5 Volts Max

OUTPUT

Zero Selection	0 or 4 mA 0 or 2 V
Temperature Coefficient	0.001%/°C typ
Test Signal Output	Add 8 mA or 4 V to output
Current Output Span	
Current	0 or 4 to +20 mA Available 0 to -0.3 mA for zero monitor
Compliance Voltage	0 to +20 Volts Available 0 to -0.3 V for zero monitor
Loop Resistance	0 to 1000 ohms
Voltage Output Span	
Voltage	0 or 2 to 10 V Available -2 V to 10 V
Maximum Load Current	5 mA
Frequency Response	
2 Poll roll off	-3dB at 10 Hz typ
Response Time	
Rise Time 10% to 90%	35 mS
To 0.1% of Final value	100 mS

COMPARATOR OUTPUT Optional with Opto22 I/O Module	
Comparative Voltage	0 to 10 V
Hysteresis Voltage	0.07 V typ
Comparator Output	see the specification of OPTO22 output module
Input/Output Isolation	300 V
BRIDGE EXCITATION SUPPLY	
Voltage Adjustment Range	5 to 10 V
Temperature Coefficient	0.001% typ at 10V
Load Current	0 to 120 mA
Remote Sense for Excitation Supply	
Current Leads Volt Drop	Max 1 V drop
Sensing Leads Resistance	Max 1 kohm
Line Regulation	Less than 0.01%, typ 0.002%
Load Regulation	Less than 0.03%, typ 0.005%
Output Noise	1 mV RMS, typ
120 Hz Bandwidth	
POWER INPUT	
	LED power on indicator
AC	115 V (90 to 130 V) / 230 V (180 to 260 V) 50/60 Hz, 10 W typ
DC	11 to 30 V, 8 W
ENVIRONMENT	
Operating Temperature	-25°C to +55°C
Storage Temperature	-25°C to +85°C
WEIGHT	
	10.5 lb (4.7 kg)
JUNCTION BOX	
	10" L x 8" W x 4" H , NEMA 4 Box or NEMA 4X Stainless Steel Box
TOTAL SIZE	
	12.5" x 9" x 4.4" (318 mm x 229 mm x 112 mm)

6. Instrument Layout

The components are assembled on one printed circuit board which is mounted inside of the NEMA 4 box. The T & B Non-Metallic Liquidtight Strain Relief Connectors are used for weatherproofing and corrosion resistance. Four connectors on one side of the box are used for load cell connections. Two connectors on another side of the box are used for output signals, relay outputs and power connections.

II. INSTALLATION

1. Unpacking the 4800

A. Item Check List

- ✓ 4800 Load Cell Summing Transmitter
- ✓ AC Power Cord
- ✓ Grounding Kit for NEMA 4 Box
- ✓ Operation Manual
- ✓ Hole Plugs

2. Mounting

Mount the NEMA 4 Box using four screws in a location where water will not drip or run directly onto it.

Connect the box to the scale frame work ground using the "Grounding Kit" and a low resistance ground strap (e.g. #10 or larger wire). A terminal "GND" on "Power Input" connector can also be used for ground connection.

3. Electrical Connection

***Note:** All the terminals are marked clearly on the printed circuit board. Be sure all terminal strip connections are tight and the cable conductors are not cut or damaged. Use strain relief connectors, tighten securely. Remove any unused strain reliefs and replace with provided hole plugs.*

A. Connect the power to Model 4800

If you use AC power line, connect the two AC power leads to "AC" pin and ground lead to "GND" pin. Set the "AC Switch" to your power line voltage (115 or 230 V) before you plug in the power cord.

If you use DC power, connect the DC power supply plus lead to "DC+" pin and negative lead to "DC-" pin.

B. Pre-set the excitation voltage

Connect "RSE.+" (Remote sensing) to "EXC.+" (Excitation), on "Remote Sense" connector "TR5", and connect "RSE.-" to "EXC.-".

Turn on the power to Model 4800. Measure the voltage at the remote sensing pins. Adjust the excitation supply voltage with the "EXC. V" potentiometer "R131".

This step is necessary to avoid overdriving the load cells.

Note that all four load cell connectors "TR1-4" use the same excitation supply in parallel, so the excitation supply voltage is always adjusted at "EXC. V" potentiometer "R131" regardless of the number of cells.

***CAUTION: Turn off the power!**

C. Connect the load cells to the Model 4800

"EXC.+" and "EXC.-" pins, see Fig.1 to Fig.3 for different applications.

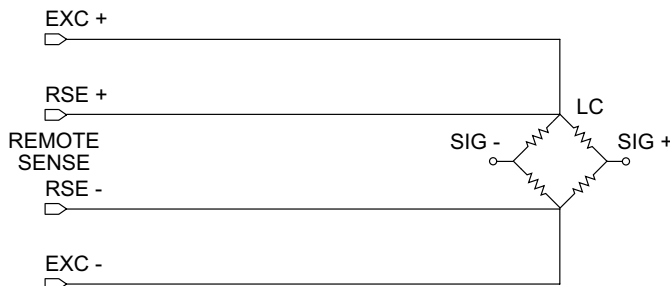

Figure 1.
Remote Sense for Single Load Cell

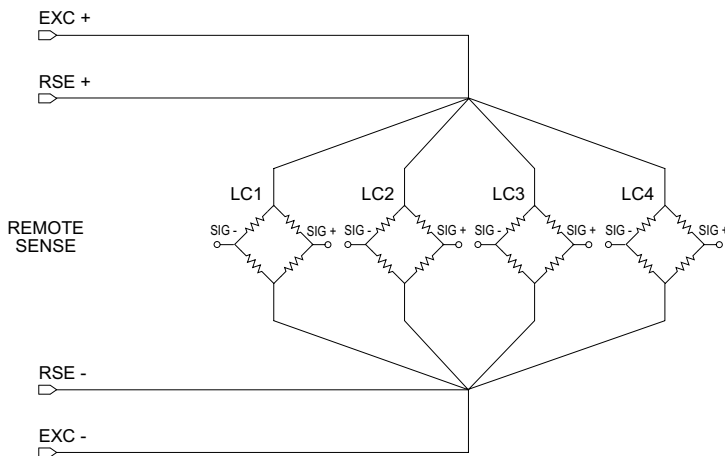

Figure 2.
Remote Sense for Multiple Load Cells

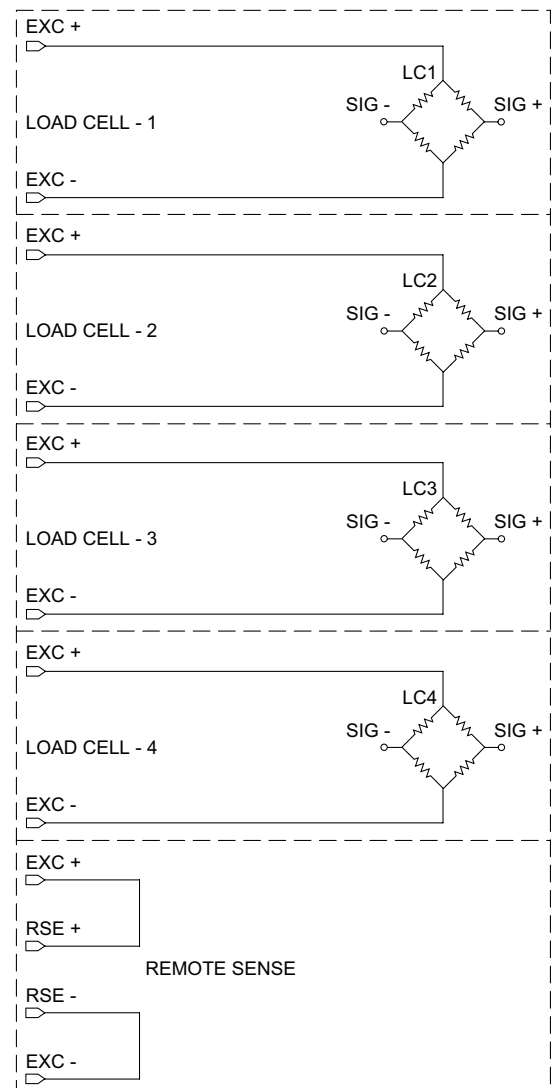

Figure 3.
Non-remote Sense for Multiple Load Cells

D. Remote Excitation

Excitation Supply is a high performance, remote sensing supply for long lead applications. Remote sensing mode is recommended for single load cell applications and also for up to four load cell applications where long leads are present.

The total voltage drop of excitation leads should be less than 1 V. An application example: if excitation leads are copper wire AWG No. 16, 1000 feet resistance is 4.016 ohm, round trip resistance is 8.032 ohm, then the voltage drop at 120 mA excitation current is less than 1 V.

If remote sensing is desired, disconnect "RSE.+" from "EXC.+", on "Remote Sense" connector "TR5", and disconnect "RSE.-" from "EXC.-".

Connect "RSE.+" and "RSE.-" to the excitation leads where you want the voltage to be controlled. Usually these two points are close to the load cell. See Fig. 2 for single load cell and Fig. 3 for multiple load cell connections.

If remote sensing is not used, skip step D.

E. Connect each load cell to the related amplifier input pins

"SIG.+" and "SIG.-" on connectors "Load Cell-1" to "Load Cell-4".

If a single load cell is used, connect it to "Load Cell-1" connector. (Other connectors "Load Cell-2 to 4" and switch "LC2 to 4" can also be used.)

All wires used in connecting up the Model 4800 should be of the same material. If any intervening connections have to be made, such as a terminal block, the terminal block connecting points should have good thermal contact so they will always be at the same temperature to minimize thermal-electric effects.

F. "SW1" has eight dip switches for four load cells.

Turn on two switches "LC1" on "SW1". This connects the cell output signals to the amplifier input.

G. We strongly recommend you use the 4800 excitation supply to ensure high accuracy. In case the amplifier is used without the 4800 excitation supply, the external power supply low side must be connected to the "EXC.-" terminal on "Remote Sense" connector.

III. Setup

1. Setting the Excitation Voltage

- A. Turn on power to the 4800.
- B. Measure the voltage at the remote sensing points or at the sense terminal on "Remote Sense" connector. Adjust the excitation supply voltage with the "EXC. V" potentiometer "R131".

2. Single Load Cell System Adjustment

- A. Select the expected full scale signal range according to table 1 with SW2-"FS1", "FS2" and "FS3". If the output from the load cell is not known, set SW2 for the 40-50 mV range.

Table 1. Input Range Selection for Full Scale

Range	0-20 mA/ 0-10V	2-10 V/ 4-20 mA	FS1	FS2	FS3
1	5 to 10 mV	5 to 8 mV	OFF	OFF	OFF
2	10 to 20 mV	8 to 16 mV	OFF	OFF	ON
3	20 to 40 mV	16 to 32 mV	OFF	ON	ON or OFF
4	40 to 50 mV	32 to 50 mV	ON	ON or OFF	ON or OFF

B. Select Zero Output

Set SW2-"4mA" on for 4 mA or 2 V output or SW2-"4mA" off for 0 mA or 0 V output. Note actual output may not equal desired value, follow the steps below for adjustment.

C. Select Tare Range on "SW2" according to Table 2.

Table 2. Tare Range Selection

	TARE 1	TARE 2
-3 to 6.5 mV	OFF	OFF
6.5 to 16 mV	OFF	ON
16 to 25 mV	ON	ON or OFF

D. Apply no load or dead weight to load cell.

E. For voltage output: Connect the "Hi" lead of a digital voltmeter to the "10V", connect the "Lo" lead of the digital voltmeter to the "O-GND" of "OUTPUT" connector "TR6".

For current output: Connect the "Hi" lead of a current meter to the "I-OUT", connect the "Lo" lead of the current meter to the current return terminal "I-RET" of "OUTPUT" connector "TR6".

There will be a small difference between current output and voltage output. Select current or voltage output for adjustment.

F. Adjust "TARE COARSE" and "TARE FINE" potentiometers for the ZERO current (0 or 4 mA) or ZERO voltage (0 or 2 V).

G. Test signal: Turn on Switch "SW2"- "8mA" to output a change of 8 mA or 4 V for monitoring system check. See Table 3.

Table 3. Calibration Output Selection

	"SW2" - "4 mA" OFF	"SW2" - "4 mA" ON
"SW2" - "8 mA" OFF	0	4 mA and/or 2 V
"SW2" - "8 mA" ON	8 mA and/or 4 V	12 mA and/or 6 V

Turn "SW2"- "8mA" off, after the completion of system check.

H. Apply rated load cell full scale load. Adjust "SENSIT.1" ("R2") to get the maximum sensitivity.

I. Apply rated load cell full scale load. Adjust "FS COARSE" and "FS FINE" (GAIN) potentiometers for the desired full scale output voltage or current. Set full scale range switches as required in Table 2.

J. Remove full scale load and check ZERO output voltage or current. Adjust "TARE FINE" potentiometer if required.

K. Recheck full scale as in Step 2.I.

3. Multiple Load Cells Adjustment (Cornering the scale)

Note: The full scale weight of a system with multiple load cells is the multiple of rated full scale of each load cell.

A. Turn on two "SW1"- "LC1" switches only, turn off other "SW1" switches. Follow steps 2.A. to 2.I.. Note: Apply a load of 20 to 100 % of the rated full scale capacity of each load cell (not the full scale of system) for corner adjustment. Record the output voltage with and without load.

B. Turn on two "SW1"-"LCn" (n=2, 3, or 4) switches only, turn off all other "SW1" switches. Apply same load as in step A. Adjust "SENSIT. n" to get the maximum sensitivity. Record the output voltages with and without load for each load cell.

C. Calculate the span, the difference of output voltage between no load and loaded for each corner load cell.

The sensitivity adjustment range for 350 ohm load cells is 7%. If the spread of the difference of output voltage between corner load cells is larger than 7%, check the mechanical installation of load cells and the specifications of load cells. Usually the corner load cells should be matched to each other within $\pm 3\%$.

D. Select the lowest cell output span as the span reference.

Do not adjust the load cell sensitivity pot for this cell.

Turn on two "SW1"-"LCn" (n=1, 2, 3, or 4) switches only. Turn off all other "SW1" switches. Apply no load and 20% to 100 % of full scale of load cell (Not system full scale). Adjust "SENSIT. n" potentiometer to lower down the sensitivity for the output span to be the same value as span reference voltage.

E. If there is no way to put known weight on each corner, apply 20 to 100 % of full scale of system load instead of 20% to 100 % of full scale of load cell. Then follow the steps A to D.

F. Turn on all "SW1"-"LC1", "LC2" "LCn" switches which are used. Remove all load and check ZERO output voltage or current. Adjust "TARE COARSE" and "TARE FINE" potentiometer for zero output.

G. Apply rated system full scale load. Adjust "FS COARSE" and "FS FINE" (GAIN) potentiometers for the desired full scale output voltage or current. Set full scale range switches as required in Table 2.

H. If necessary, repeat step 3.E and 3.F.

***Note:** Do not try to equalize the dead load outputs of each cell. The dead load does not need to be the same for proper operation of the summing board.*

4. Troubleshooting

A. The scale seems to be reading incorrectly

- a. Check for correct wiring.
- b. Unload the scale and check for a zero reading.
- c. Check the input range switches according to Table 2.
- d. Be sure that the object being weighed is completely on the scale.

B. The scale corner readings are not equal

- a. Repeat step 3. multiple load cells adjustment.
- b. Check the installation of load cells.
- c. Check the load cells for damage.

C. The scale readings drift rapidly

- a. Check for water in the junction box.
- b. Isolate one load cell at a time from the summing box by turning off the two related switches "LCn" (n=1 to 4). If the scale reading becomes stable, then the isolated load cell is probably defective or not installed properly.
- c. Use a load cell simulator to verify that the 4800 is stable and operating correctly.

D. Test the load cell zero shift

- a. Remove the load from the load cell.
- b. Turn on the two related switches "LCn", turn off all other switches.
- c. Measure the output voltage on "Output" connector. If it is less than 15 % of full scale output, it is not zero shifted. If the output is 15 to 50 % of full scale, the load cell has been zero shifted, but will probably still work. If the output is larger than 50 % of full scale, the load cell should be replaced with a known good unit. If the zero shift of the load cell is caused by a mechanical overload, the reason for the overload should be determined before a new load cell is installed.

E. Test load cell resistance

- a. Disconnect the load cells from the junction box.
- b. Measure the resistances of load cell and compare to the load cell specifications. Water leakage into the load cell or damaged cable can cause problems.
- c. If a load cell does not pass the resistance test, replace it with a known good unit.
- d. Defective load cells can usually be repaired.

IV. OPTIONS

1. Enclosures

4800-W4: Continuous Hinge NEMA 4 Box

4800-WS: Continuous Hinge NEMA 4 Stainless Steel Box

2. Dual Set Point Relays

A. Opto-22 G4ODC5 *

Opto-22 G4OAC5 *

**Not included with the 4800*

B. Installation

Plug the Opto-22 output modules into "RELAY1" and "RELAY2" on the printed circuit board. Tighten the screw on top of the module lightly.

C. Adjusting Set Point Values

If you need the Relay outputs, connect the "Hi" lead of a digital voltmeter to the "TP1". Connect the "Lo" lead of the digital voltmeter to the "O-GND" on "OUTPUT" connector "TR6". Test the voltage at "TP1" and adjust the "COMP. V1" potentiometer "R66" to set the Comparator voltage for the low set point. If the output voltage at "OUTPUT" connector "TR6" is lower than the Comparator voltage at "TP1", this means the output is lower than the low set point, and the output of Relay 1 will be "ON". The two "RL1" on "RELAY OUTPUT" connector "TR7" are the Opto-22 Output contacts.

Use the digital voltmeter to set the voltage at "TP2" with "COMP. V2" potentiometer "R75" for high set point. If the output voltage at "OUTPUT" on connector "TR6" is higher than the Comparator voltage at "TP2", this means the output is higher than high set point, and the output of Relay 2 will be "ON". The two "RL2" on "RELAY OUTPUT" connector "TR7" are the Opto-22 Output contacts.

In order to prevent relay chatter, typically there are 0.07 V hysteresis voltage. There may be a very small difference between the output voltage and the voltage at "TP1" or "TP2" for turn on or off. The output voltage for turn on or off can be set precisely by adjusting the "COMP. V1" potentiometer "R66" for the low set point or "COMP. V2" potentiometer "R75" for high set point.

MODEL 4800
LOAD CELL SUMMING TRANSMITTER

OPERATION MANUAL

C0001

1 . 8 . 0 1