

# Model 545 and 546 Voltensors



## Description

The Models 545 and 546 are precision dual set voltage comparators with a differential amplifier front end and three separate outputs. Pin select the input range you need from 10 mV to 1V on the 545 or 100 mV to 10V on the 546. Set your comparator window anywhere in the selected range and load the three outputs up to 100 mA. These Voltensors are ideal for directly monitoring strain gages, load cells, thermocouples, power supplies, etc.

## Voltensor Selection

The basic difference between the 545 and 546 is the input signal range. If your trip-point will never exceed  $\pm 1$  volt, then the 545 would be the best choice. For trip levels up to  $\pm 10$  Volts, the 546 is best. Signals over  $\pm 10$  Volts can be divided down and monitored with the 546.

## Basic Operation

The 545 and 546 are basically divided into four sections. These are the input, the amplifier, the comparator, and the outputs.

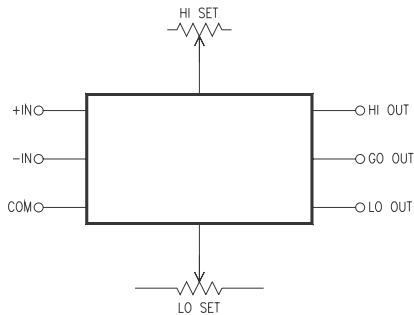

FIGURE 1. Simplified Diagram for Models 545 and 546

## The Input Section

The inputs to both of these Voltensors can be either single-ended or differential. When the input is single-ended, connect your + input to pin 21 and the other side to signal common (pin 24). See Figure 2. The -in input (pin 22) must be connected to

## Features

- Dual Set-Point (High and Low)
- Triple Output (HI, GO, LO)
  - High Level Output (100 mA)
- Versatile Input Amplifier
  - Differential Input
  - Pin-Selectable Ranges
  - High Input Impedance
- Variable Hysteresis
- Latching Capability

## Applications

- Quality Control HI-GO-LO Testing
- Computer Control System Backup
- Instrument Trip Points
- Process Control
- Power Supply Monitor

common in single-ended applications. If your signal source has an impedance of greater than 10 k $\Omega$ , better balance and drift can be obtained by connecting a resistor of equal impedance from pin 22 to common instead of a short to common (see figure 3).

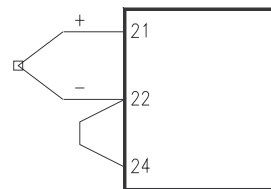

FIGURE 2. Single-Ended Connections

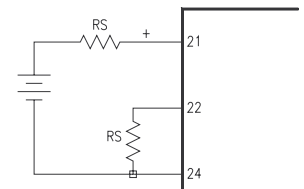

FIGURE 3. High Source Impedance Connections

When the input is differential, connect your positive differential signal to pin 21 and the negative signal to pin 22. The 545 and 546 will operate with common mode voltages as high as  $\pm 10$  Volts. Be sure and connect the common of your differential circuit to the common of the Voltensor (see Figures 4 and 5).

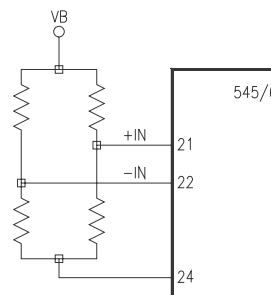

FIGURE 4. Bridge Differential Connection

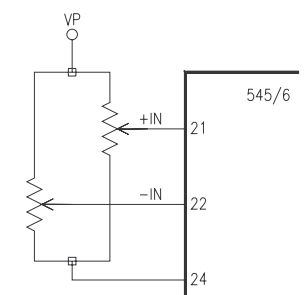

FIGURE 5. Potentiometer Differential Connection

# Model 545 and 546 Voltensors

## The Amplifier Section

The input amplifier of the 545 and 546 is a true instrumentation amplifier. This amplifier simply multiplies the difference between the input pins by the gain. The gain is set by selecting the gain pin required. The gain of the 545 is 10 to 1000 and the 546 is 1 to 100. The pin selection, trip range and gain of the two Voltensors is shown on the following table.

Model	Trip Range	Gain	Pin Program
545	0 - 10 mV	1000	Jumper pin 19-20
	0 - 100 mV	100	Jumper pin 18-20
	0 - 1V	10	No Jumper Req'd.
546	0 - 100 mV	100	Jumper pin 19-20
	0 - 1V	10	Jumper pin 18-20
	0 - 10V	1	No Jumper Req'd.

The amplifier input voltage on both the 545 and 546 can be as high as  $\pm 100$  Volts without damage. The trip point range is the main criteria for your Voltensor selection and not the maximum input voltage.

## The Comparator Section

There are two comparators in the 545 and 546. They monitor the output of the input amplifier for a signal too high and for a signal too low. The actual trip point of each comparator is set by the voltage on its associated potentiometer. The relationship between the trip point voltage and the input is the potentiometer voltage divided by the gain of the amplifier. If, for example, the pot voltage was 6.5 Volts and the input amplifier had a gain of ten, the trip point would be approximately 650 mV. Both the high and low comparators can be externally programmed to latch and to provide a variable hysteresis.

## The Output Section

### Current-Sinking Mode

Connections for current-sinking operation are shown in Figure 6. Each of the three outputs, HI, GO and LO, are identical and each is independent. When the base drive from the comparison stages (or from the GO logic) swings positive, the output transistor saturates and the load current flows through the load and output transistor. The voltage across the collector-to-emitter of the saturated transistor is very low and this logic state is referred to as the "low state." Output voltage in the low state is approximately  $0.1V + I_L \times R_{sat}$ , where  $I_L$  is the load current and  $R_{sat}$  is the saturation impedance (typically  $5\Omega$ ). The saturation voltage at maximum load current is specified to be less than 0.7V. When the base drive from the comparison stages swings negative, the output transistor becomes cut-off and the load current is switched off. The output voltage then rises to the positive load voltage. Leakage from the cut-off output transistor will be less than  $1 \mu A$ .

Power dissipation in the current-sinking mode is very low. In the low state the output voltage is small although the current is high. In the high state, the output voltage is high, but the load current is small. For both conditions, the product of output-voltage-times-loadcurrent is small and power dissipation is minimal. For this reason, current-sinking is generally preferred.

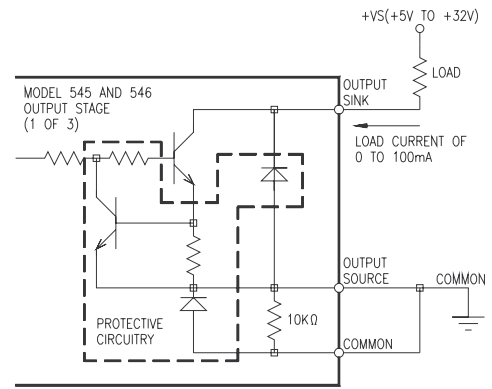

**FIGURE 6.** Models 545 and 546, Connected for Current-Sinking Mode (One of Three Outputs)

### Current-Sourcing Mode

Any of the three outputs, HI, GO, and LO, can be connected as emitter-followers (see Figure 7). Each output is identical and is independent of the other output stages. The output voltages with all three connected as emitter followers are shown in Figure 7. Each output can source up to +20mA and each is short-circuit protected.

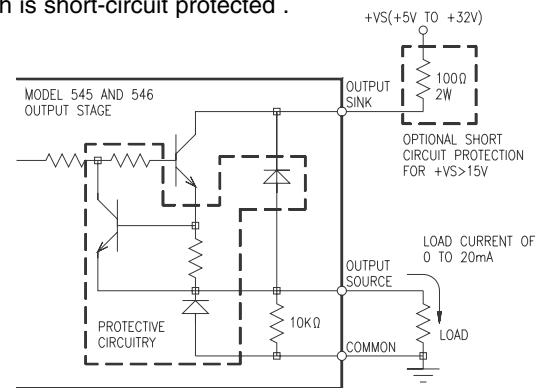

**FIGURE 7.** Models 545 and 546, Connected for Current-Sourcing Mode (One of Three Outputs)

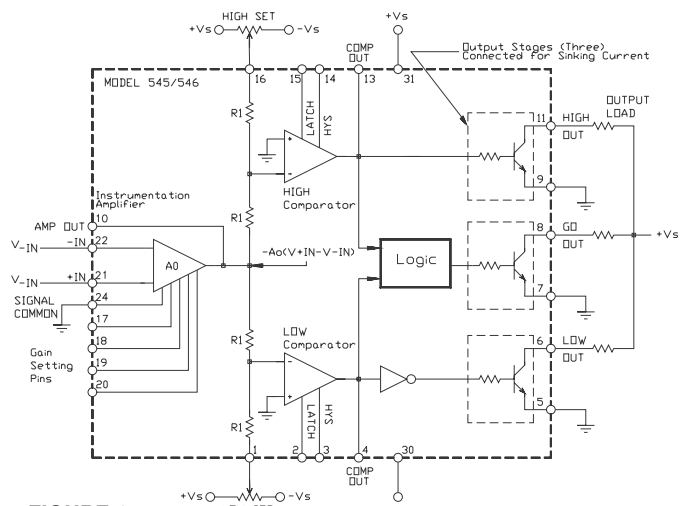

**FIGURE 8.** Simplified Circuit Diagram for Models 545 and 546

# Model 545 and 546 Voltensors

## Operation

### Set-Point Adjustment

The set-point voltages can be derived from any DC voltage source. In adjusting the set-point voltages, it is best to start with the high set at a high positive value and the low set at a maximum negative value. This is done to prevent crossing over (low above high). The high set voltage must always be more positive than the low set voltage for proper operation.

On the mounting kits, there will be a jumper from the pot wipers to the proper module pins. To operate with remotely-set potentiometers on Models MK 376, 377, and 378, remove the jumpers J1 and J3 and insert jumpers J2 and J4. On the Model MK379, the high and low set points must be set on the PC card rather than remotely.

### Hysteresis

Hysteresis, or ON/OFF differential, is defined as a difference in comparator switching point depending on input signal direction (positive or negative). A small amount of hysteresis is provided internally. To increase the hysteresis, connect a resistor (approximately 220K) between the appropriate pins (pin 13 or 14 for the high comparator and pin 4 to 3 for the low comparator).

### Grounding Considerations

Power Common (pin 29) and Signal Common (pin 24), are connected internally, but noise is minimized by routing the Power Common line directly to the common of the  $\pm 15V$  power supply being used to power the Model 545.

### Latching

The high comparator can be made to latch by connecting the high comparator output (pin 13) to the high comparator latch in (pin 15). This will cause the high comparator to remain in the on state after it has once been tripped. The comparator can be reset (unlatched) by opening the connection between pins 13 and 15 or by temporarily removing power.

The low comparator can be made to latch in a similar manner. Connect pin 4 to pin 2, and disconnect to reset. This circuit also latches when switched to the on state.

For both comparators, the on state refers to one of two conditions: (1) Where the output transistor is saturated (low state) if the output is connected for current-sinking mode, or (2) Where the output voltage is high if the output is connected for current-sourcing. One advantage of the Model 545 and 546 Multifunction Voltensor is that the high and low comparators can be latched independently of each other and independently of the output mode of operation.

## Specifications

Model	545	546
Input Trip Point Range	Pin selectable for $\pm 10$ mV $\pm 100$ mV or $\pm 1V$ Range	Pin selectable for $\pm 100$ mV $\pm 1V$ or $\pm 10V$ Range
Trip Point Stability	$\pm 5 \mu V/^{\circ}C$ RTI	$\pm 50 \mu V/^{\circ}C$ RTI
Common Mode Rejection	100 dB up to $\pm 10V$ Input	
Sensitivity & Repeatability	10 $\mu V$ RTI	100 $\mu V$ RTI
ON/OFF Differential (Hysteresis)	0.1% of range. Externally adj. to greater than 10%	
Input Impedance	10 megohm Diff. 500 megohm C.M.	
Max. Input Voltage	$\pm 100V$ for less than 0.1 sec	
Output (Each Output)	When connected as current sink:	When connected as current source:
Output Voltage		
HIGH State	+Supply Voltage [1]	+10V min. at 20mA
LOW State	+0.7V max. at 100 mA	+0.1V max.
Output Impedance		
HIGH State	Open collector with 1 $\mu A$ Leakage	10 ohm max.
LOW State	Saturated Transistor with Impedance of 5 ohm	10 ohm max.
<b>Response Time</b>		
Operating Time	300 $\mu s$ for $\pm 10$ mV Range 100 $\mu s$ for $\pm 100$ mV Range 100 $\mu s$ for $\pm 1V$ Range 100 $\mu s$ for $\pm 10V$ Range	
Output Rise and Fall Time	30 $\mu s$	
<b>Power Requirements</b>		
Supply Voltage Range ( $\pm V_s$ )	$\pm 15V$ ( $\pm 5\%$ ) [1]	
Quiescent Current Drain	$\pm 25$ mA	
Temperature Range	0 $^{\circ}$ to +70 $^{\circ}C$	
Size (inches)	2.0" x 2.0" x 0.6"	

[1] The module operates from  $\pm 15V$  power, but the positive supply connection to the output stages can be any voltage from +5V to +32V. On the mounting kits, the supply voltage is committed to  $\pm 15V$  and the relays are chosen for 15V operation.

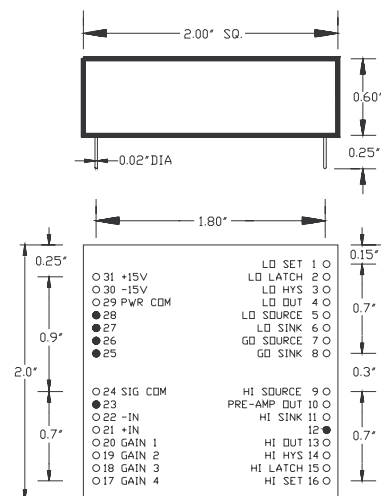

Shaded pins not installed. Shown for position only.

**FIGURE 9.**  
Outline Dimensions and Pin Assignments for Models 545/546

# Model 545 and 546 Voltensors

## Mounting Kits

Four mounting kits are offered for the Model 545/546 module. Each mounting kit consists of a PC card, adjustment pots, and a 15-pin mating kit connector. Two of the mounting kits also have low-profile relays mounted on the PC card. Mounting kits can be ordered with the Model 545/546 module installed or can be ordered separately. The price of the mounting kits includes the pots, relays, and connector. The combined price is computed by adding the price of the module to the price of the mounting kit.

The mounting kits all accept one Model 545/546 module. Trimming potentiometers are included for setting the high and low trip points. Gain of the input amplifier may be changed by jumpering on the mounting kit, or by adding a fixed resistor. Also, hysteresis can be increased by adding impedance

across terminals provided on the mounting kits. The four mounting kits provide a choice of output configuration. The differences and features of each mounting kit are shown below.

## Relays

The relays used are a low-profile SPDT type. Contact rating is 1A at 26 VDC or 0.5A at 115 VAC with a resistive load. For inductive loads derate by 50%. Coil impedance is 440 ohms  $\pm 10\%$ . response time is 10 milliseconds. Height is 0.415".

## Model 015 Connector

A 15-pin mating connector with edge guides is supplied with each mounting kit. A diagram of the connector is shown in Figure 16.

## Model MK376

The three outputs are connected for current-sinking operation. This model has provision for external remote adjustment of set-points and external latch/unlatching operation .

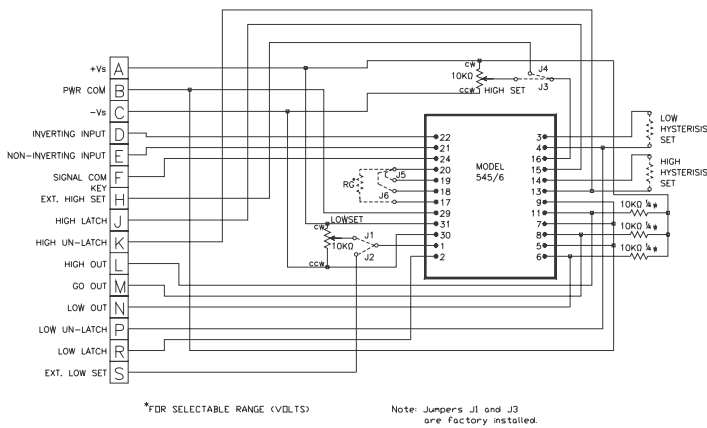

FIGURE 10. MK376 Circuit Drawing

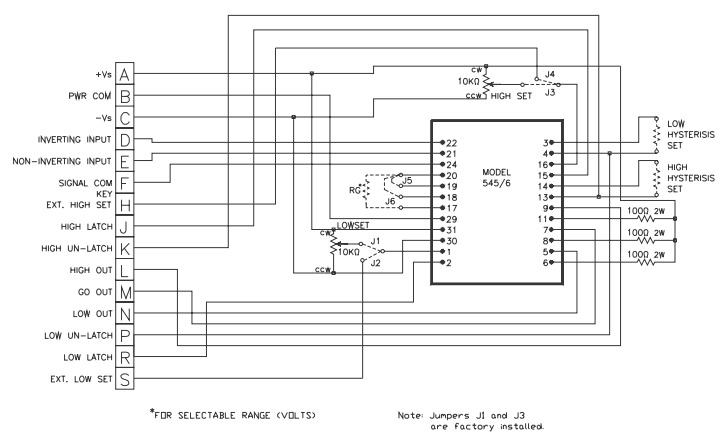

FIGURE 12. MK377 Circuit Drawing

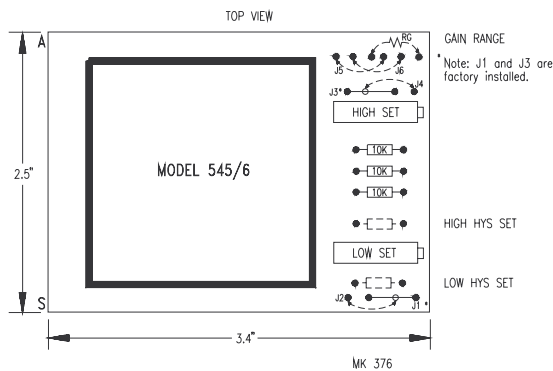

FIGURE 11. MK376 Outline Drawing

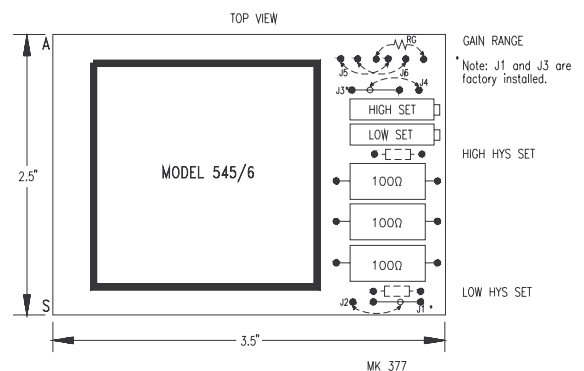

FIGURE 13. MK377 Outline Drawing

# Model 545 and 546 Volt sensors

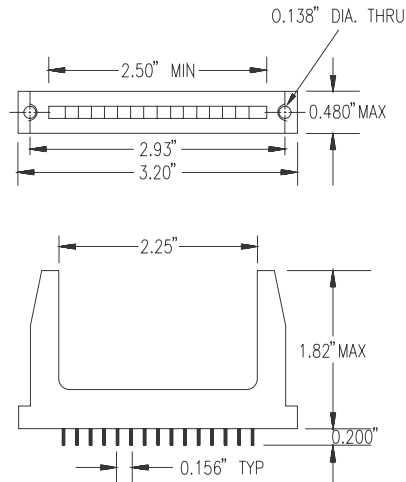

FIGURE 16. 15-pin Mating Connector for Model 545/546 Mounting Kits.

## Model MK378

This mounting kit has two low-profile relays mounted on the PC board; one for the HI output and one for the LO output. The outputs are connected for current-sinking mode of operation.

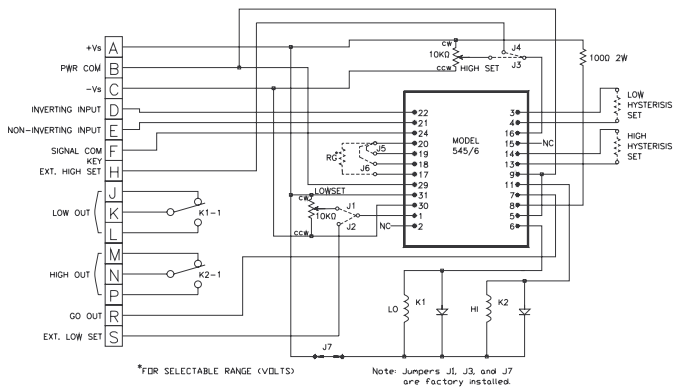

FIGURE 14. MK378 Circuit Drawing

## Model MK379

Relays are provided for all three outputs; HI, GO, and LO on this model. Each set of contacts is brought out to the connector.

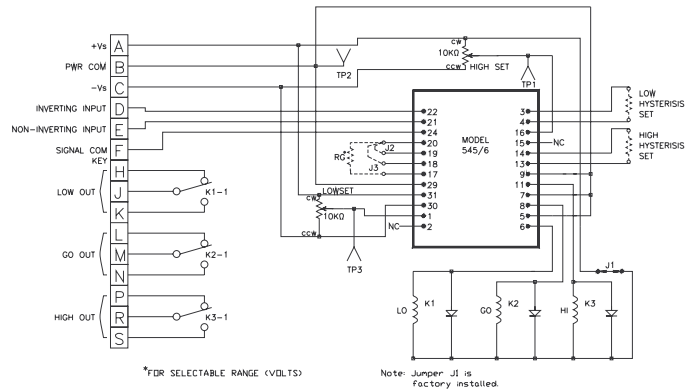

FIGURE 17. MK379 Circuit Drawing

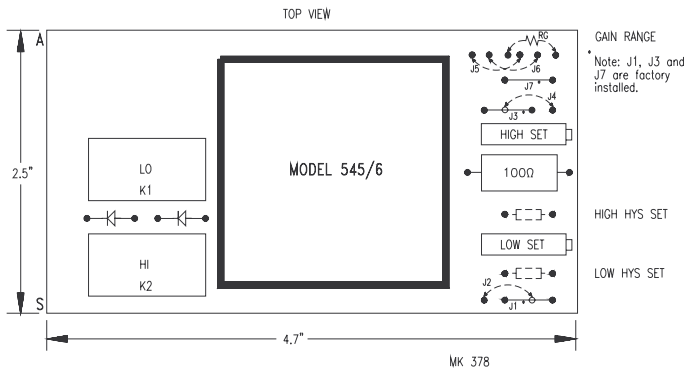

FIGURE 15. MK378 Outline Drawing

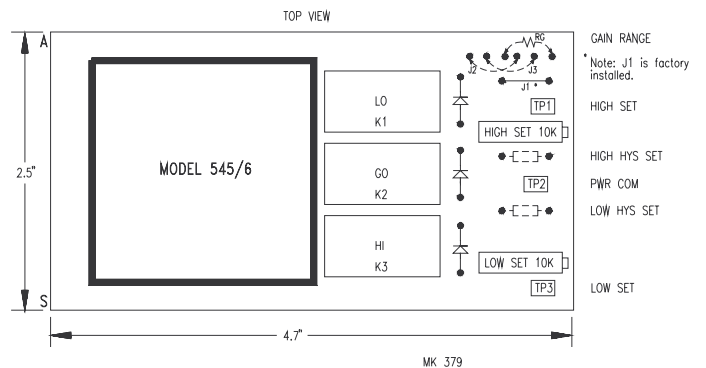

FIGURE 18. MK379 Outline Drawing