



Description

The EFIL-28 Module is an EMI Filter designed for use with Calnex DC/DC Converters. Built in a 1/2 brick package for systems with 24VDC and 28VDC nominal input, the EFIL-28 module can provide filtering for up to two Calnex DC/DC Converters.

Features

- Meets the requirements of MIL-STD-461E, CE101 and CE102
- Designed for systems with 28VDC nominal input voltage
- 1/2 brick package (2.28" x 2.40" x 0.50")
- Rated up to 200 Watts
- Aluminum substrate technology
- All ceramic solution
- Common mode and differential mode filtering
- All applicable materials used are a minimum of UL94V-0 rated. Designed to meet UL60950.
- Excellent MTBF
- Five year warranty
- Available with RoHS compliant construction, simply add "(RoHS)" after the part number i.e. EFIL-28 (RoHS)
- Optional Case- Add "-T" to the end of the part number to order the Efil-28 with a 0.55" tall case. i.e EFIL-28-T or EFIL-28-T (RoHS).

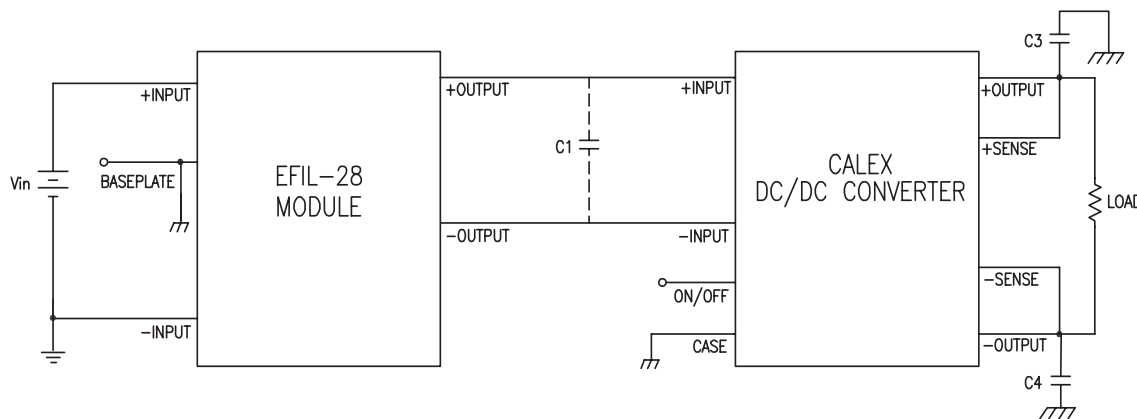

Figure 1. EFIL-28 Connection Diagram

CBAM™ EFIL-28

All parameters measured $T_A=25^{\circ}\text{C}$, and 200W of output power unless otherwise noted.

Input Parameters			
Model		EFIL-28	Units
Input Voltage Range	MIN	9.5	VDC
	TYP	28	
	MAX	36	
Input Overvoltage 100ms	MAX	50	VDC
Reverse Polarity Protection		None (1)	
Input Current	MAX	20	A
Efficiency	TYP	99	%
Recommended Input Fuse (2)			
Output Parameters			
Output Voltage		$V_{out} = V_{in} - (I_{in} \times R_{dc})$	VDC
DC Resistance (Rdc)	TYP	5	mOhm
Output Power (4) (5)	MAX	200	W
External Output Capacitance Required (5) (6)		See Table 1	
Electromagnetic Compliance (7)			
		Standard	Test
Conducted Emissions		MIL-STD-461E	CE101, CE102

Notes:

- (1) Reverse Polarity Protection: Reverse polarity will NOT damage the module. However, precautions must be taken to ensure downstream circuitry is protected. Calex HEW series DC/DC converters implement reverse polarity protection.
- (2) Refer to the CALEX Application Notes for information on fusing.
- (3) Thermal impedance is tested with the module mounted vertically and facing another printed circuit board 1/2 inch away.
- (4) Contact the factory for higher output power capabilities.
- (5) Due to the negative input resistance characteristics of DC/DC converters, the addition of an input filter may cause instability. To ensure a stable system, the output impedance of the filter must be smaller in magnitude than the converter input impedance. This can be ensured with the addition of an external capacitor connected to the input of the converter. Under normal operating conditions, specified as 28VDC input at 200 Watts, the EFIL-28 does not require any external capacitance.
- (6) Due to the added inductance (50 μH) of the Line Impedance Stabilization Network (LISN) used in MIL-STD-461E testing, capacitor C1 is required to maintain converter stability. See Figures 2 and 3.
- (7) Measurements comply with the requirements set forth in MIL-STD-461E, CE101 and CE102.
- (8) The case thermal impedance is defined as the case temperature rise over ambient per package watt dissipated.
- (9) Isolation is measured by applying a DC voltage between pins and baseplate.
- (10) Calex CBAM™ modules are designed to withstand most solder/wash processes. Careful attention should be used when assessing the applicability in your specific manufacturing process. The CBAM™ modules are not hermetically sealed.
- (11) Torque fasteners into threaded mounting inserts at 12 in.oz. or less. Greater torque may result in damage to the unit and void the warranty.
- (12) MTBF is calculated based on MIL-HDBK-217F under the following conditions:
 Reliability prediction method = Part Stress Analysis
 Baseplate temperature = 40°C
 Environment = Ground, Benign
- (13) Available with RoHS and Non-RoHS construction, contact factory for details.
- (14) RoHS Compliance:
 See Calex Website www.calex.com/RoHS.html for the complete RoHS Compliance statement.
 The RoHS marking is as follows.



CBAM™ EFIL-28

General Specifications			
Model		EFIL-28	Units
Isolation			
Baseplate to Pins (9)	MIN	700	VDC
Environmental			
Baseplate Operating Temp Range	MIN MAX	-40 100	°C
Storage Temperature Range	MIN MAX	-40 120	°C
Case Thermal Impedance (3), (8)	TYP	7	°C/Watt
MTBF MIL-STD-217F (12)		710,705	h
General			
Unit Weight	TYP	95	g
Case Dimension		2.28" x 2.40" x 0.50"	
Optional Case "-T" models		2.28" x 2.40" x 0.55"	
Torque on Mounting Inserts (11)	MAX	12 in. oz.	

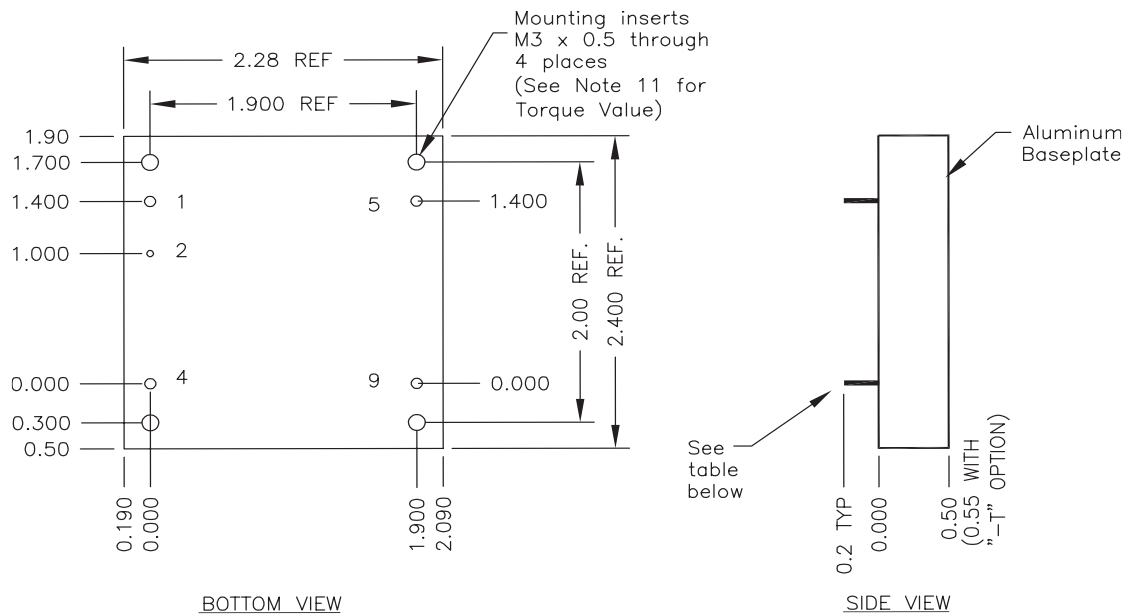

Pin	Pin Dia.	Function
1	0.080"	- INPUT
2	0.040"	BASEPLATE
4	0.080"	+ INPUT
5	0.080"	- OUTPUT
9	0.080"	+ OUTPUT

Mechanical tolerances unless otherwise noted:
 X.XX dimensions: ±0.020 inches
 X.XXX dimensions: ±0.005 inches

Table 1. External Components

Component	Rating / Type	Drawing	Notes
C1	No Capacitor Required	Figure 1.	For $V_{in} \geq 18$ VDC
	220 μ F, 100 VDC, Electrolytic	Figure 2 and 3	For $9.5 \leq V_{in} < 18$ VDC and with EMI Test Setup. See Notes (5) (6)
C3, C4	0.01 μ F, 1000 VDC, Ceramic	Figure 1, 2 and 3	Converter Common mode capacitors

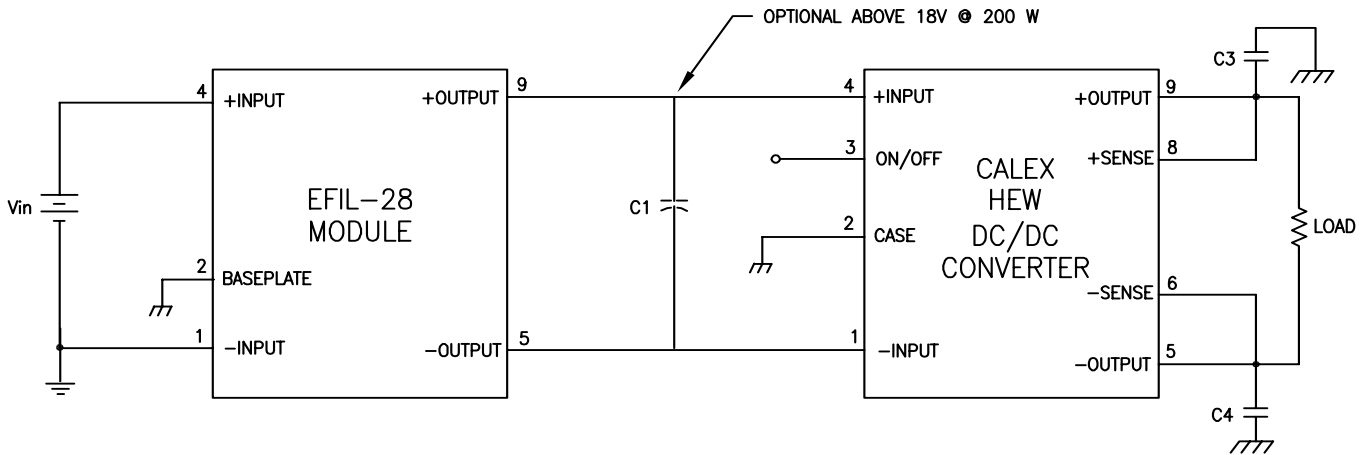

Figure 2. EFIL-28 with Calex HEW Series DC/DC Converter

MIL-STD-461E Conducted Emissions Results CE102, 28VDC Input

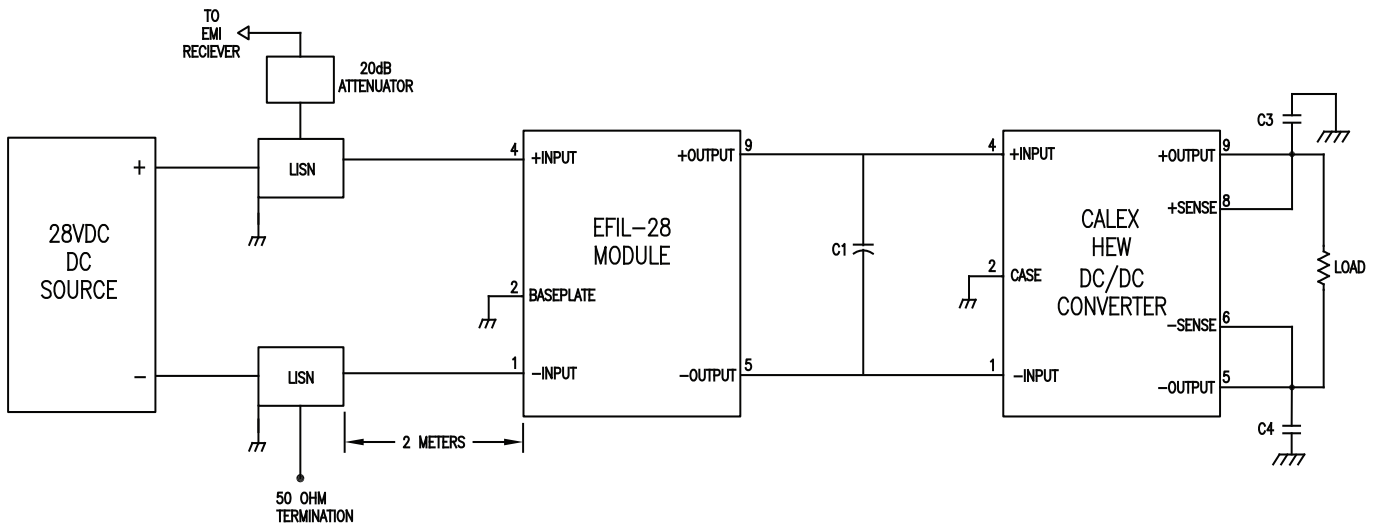
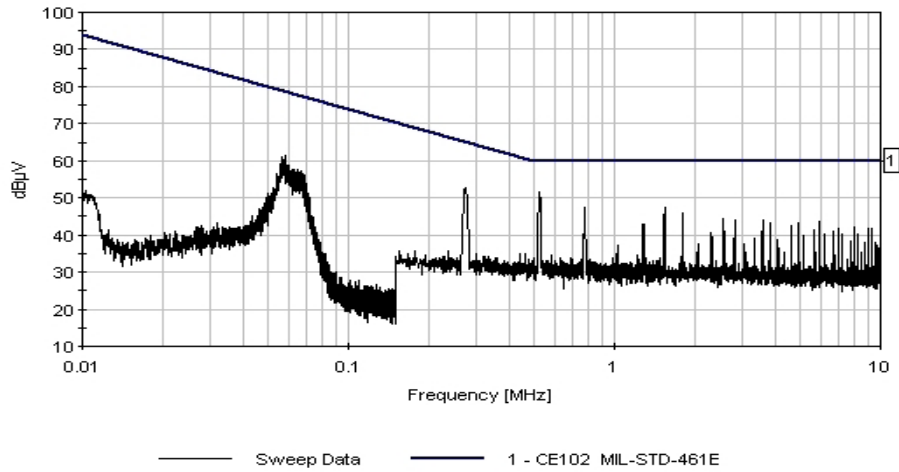
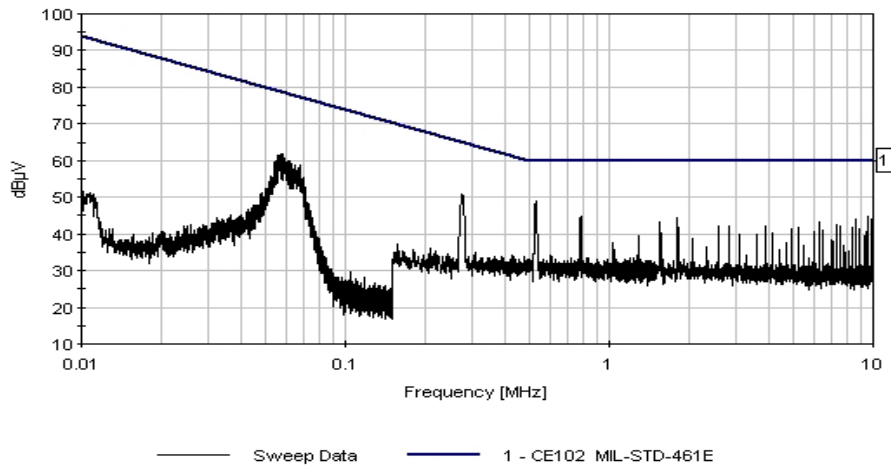

Figure 3. MIL-STD-461E CE102 Test Configuration



EFIL-28 with 24S3.30HEW, Full Load



EFIL-28 with 24S5.30HEW, Full Load

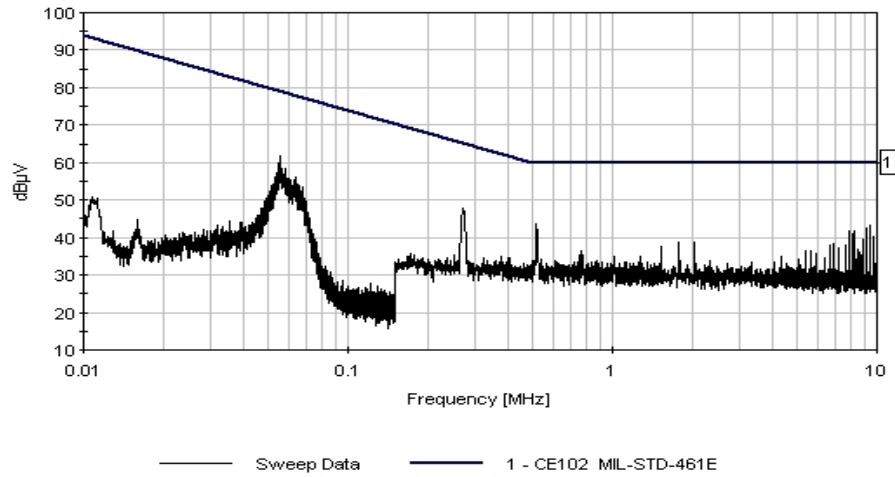

EFIL-28 with 24S12.12HEW, Full Load

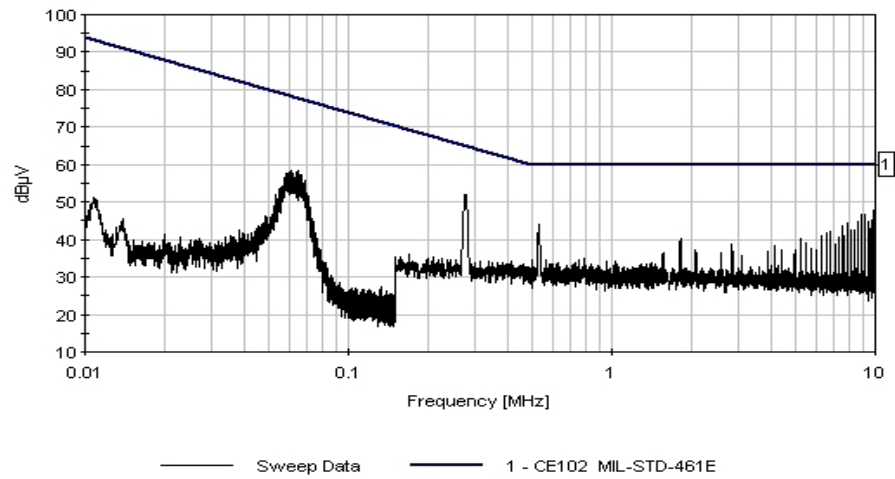

EFIL-28 with 24S15.10HEW, Full Load

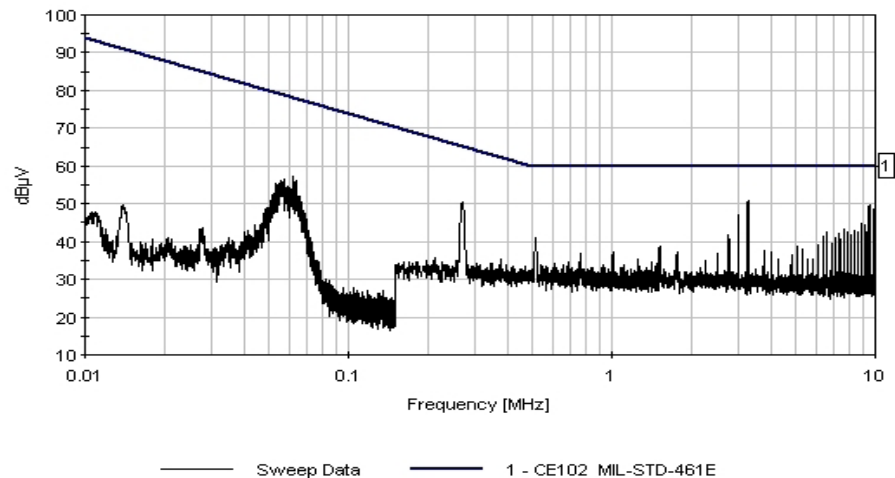

EFIL-28 with 24S24.6HEW, Full Load

MIL-STD-461E Conducted Emissions Results CE101, 28VDC Input

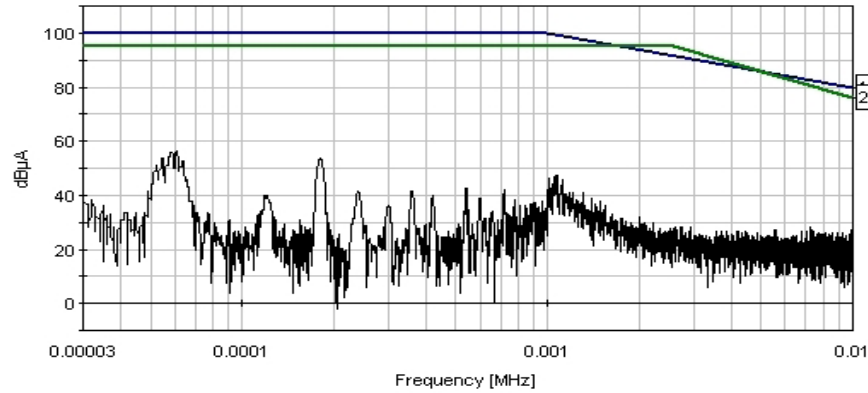

— Sweep Data — 1 - CE101 MIL-STD 461E Aircraft
 — 2 - CE101 Submarine Applications, DC

EFIL-28 with 24S3.30HEW, Full Load

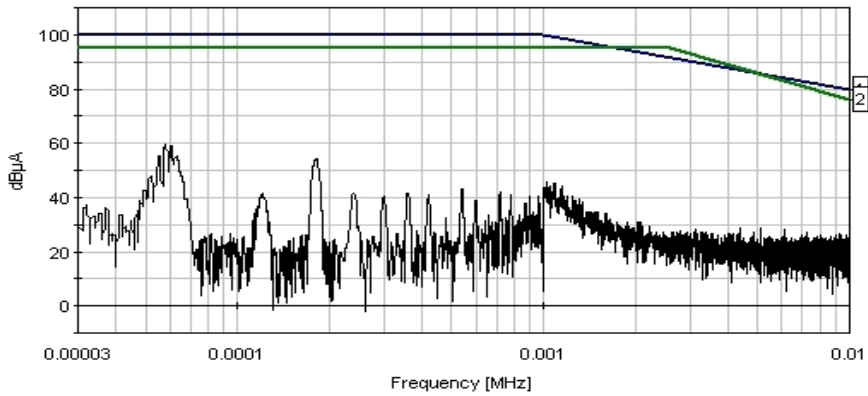

— Sweep Data — 1 - CE101 MIL-STD 461E Aircraft
 — 2 - CE101 Submarine Applications, DC

EFIL-28 with 24S5.30HEW, Full Load

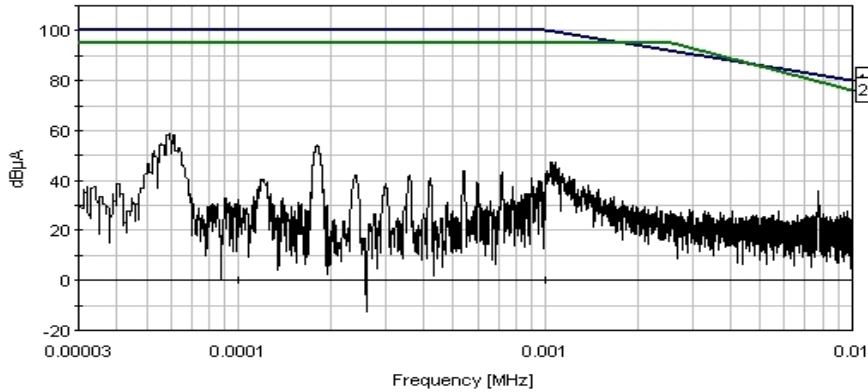

— Sweep Data — 1 - CE101 MIL-STD 461E Aircraft
 — 2 - CE101 Submarine Applications, DC

EFIL-28 with 24S12.12HEW, Full Load

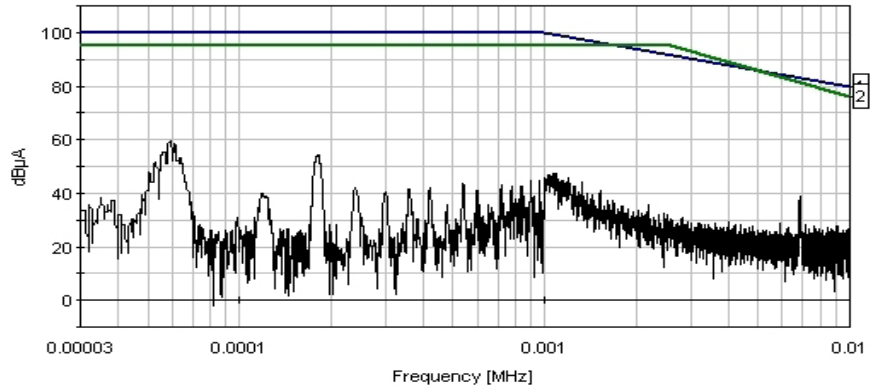

— Sweep Data
 — 1 - CE101 MIL-STD 461E Aircraft
 — 2 - CE101 Submarine Applications, DC

EFIL-28 with 24S15.10HEW, Full Load

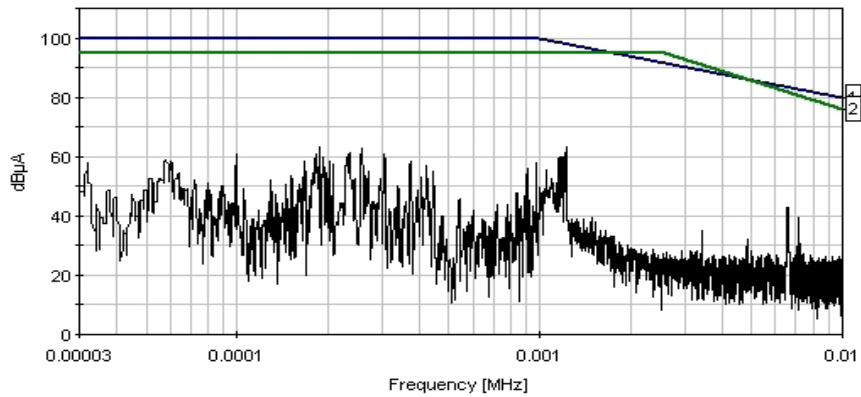

— Sweep Data
 — 1 - CE101 MIL-STD 461E Aircraft
 — 2 - CE101 Submarine Applications, DC

EFIL-28 with 24S24.6HEW, Full Load

EFIL-28 Application Section

Filter Operation

Care must be taken when using an input filter in front of any DC/DC converter. The negative input resistance characteristic of the converter can cause instability if the output impedance of the filter is larger (in magnitude) than the input resistance of the converter. To make certain this does not occur, a properly sized, low ESR electrolytic capacitor is connected to the input of the converter. This effectively drops the impedance the converter “sees” looking out of its input pins. This behavior will be at its worst at low line voltage conditions, a result of the constant power characteristic of the DC/DC converter. The lower input voltage leads to a larger input current, thus decreasing the input impedance of the converter. As a result, a larger value capacitor is required across the input. Table 1 on page 4 shows the capacitance required for proper operation. This assumes that the DC source providing the power has sufficiently low impedance. Most adequately sized power supplies or batteries should not have a problem with this matter.

Inductance of the input line may also contribute to instability. In the case of MIL-STD-461E, a LISN with 50μH of inductance is required for testing. To compensate for the inductance, a low ESR electrolytic capacitor was connected between the filter and converter; (see Table 1 and Figure 3). In addition, consider temperature range requirements. Electrolytic capacitors decrease in capacitance as temperature decreases, therefore a larger value may be necessary to account for worst-case conditions. The EFIL-28 is designed to meet MIL-STD-461E CE101 and CE102 requirements at 25°C.

Baseplate Connection

For best EMI performance, it is recommended to mount both the EFIL-28 and the Calex Converter directly to chassis ground. This results in a low impedance path from the internal EMI ground to chassis ground. If this is not possible, connect to chassis ground via the “Baseplate” pin on the EFIL-28 and the “Case” pin on the Calex Converter. The use of heavy gauge wire and the shortest possible path will minimize the impedance and improve performance.

Using Remote ON/OFF

Some Calex Converters use a remote ON/OFF function for conserving battery power or limiting inrush current when the converter is used in pulsed applications. The reference for this pin is the -Input of the converter. When implementing the Remote ON/OFF with the EFIL-28 module connected, an isolated relay or optocoupler is necessary. This is due to the use of a common mode inductor in the EFIL-28. Any DC current bypassed from the filter may cause saturation of this inductor and will severely degrade the filtering performance.

See Figure 4 and 5 for recommended circuits.

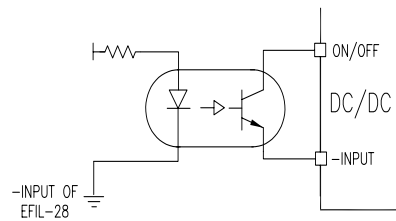

Figure 4.
Isolated ON/OFF driver using an optocoupler

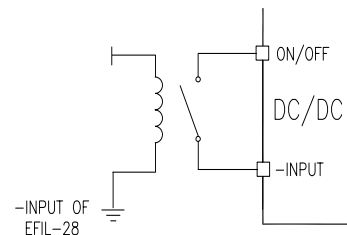

Figure 5.
Low power relay which also offers isolation

Using Two Calex Converters

It is possible to effectively filter up to two (2) Calex DC/DC converters using one (1) EFIL-28 module. However, the EFIL-28 maximum power rating of 200W must not be exceeded. This results in operating 2 converters at less than their maximum power output. With 28VDC input, this means approximately 7.2 amperes through the EFIL-28. Another precaution that must be taken is the addition of external capacitance between the filter and converters. Figure 6 shows the connection diagram with the required external capacitors. For operation below 28VDC input, these capacitors will need to increase to 470 μ F each. Note the external Y-capacitors at each converter output and at the input of the second converter. Contact the factory for filters with increased output power capabilities.

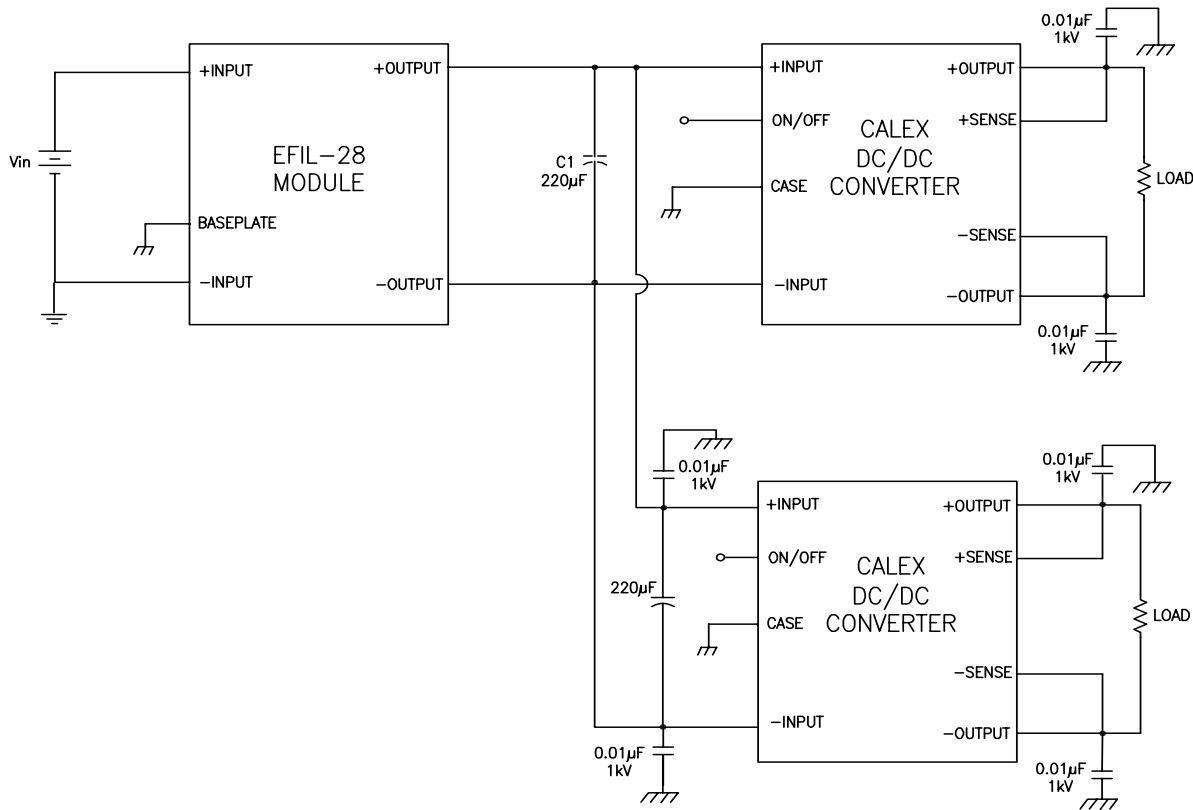
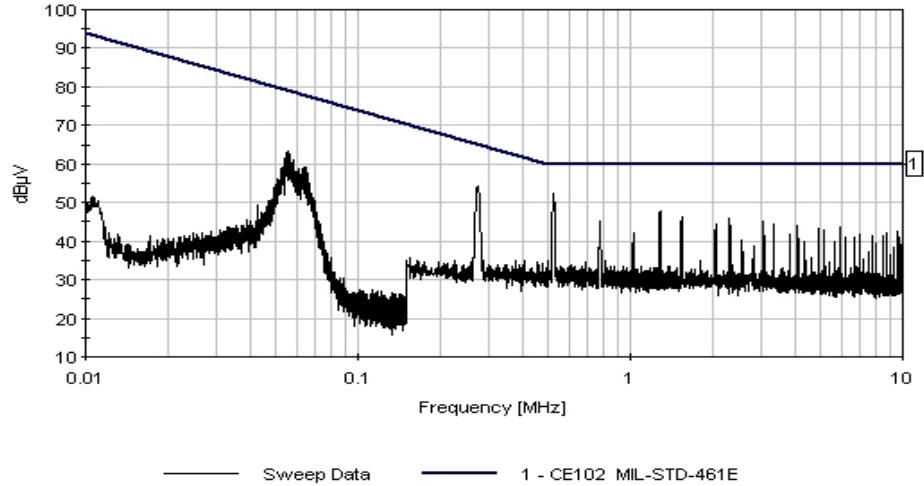

Figure 6. Connection diagram for 2 Calex DC/DC Converters

Additional Data:

MIL-STD-461E Conducted Emissions Results CE102, 24VDC Input



EFIL-28 with 24S3.30HEW, 24VDC Input, Full Load

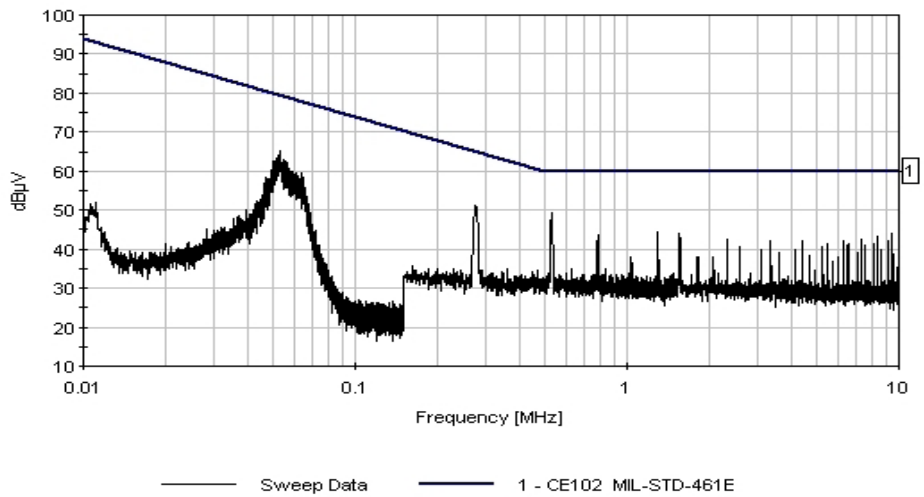

EFIL-28 with 24S5.30HEW, 24VDC Input, Full Load

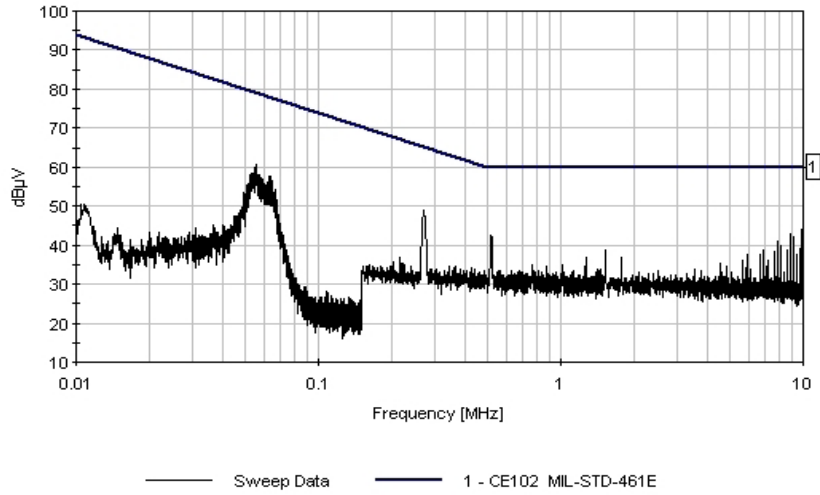

EFIL-28 with 24S12.12HEW, 24VDC Input, Full Load

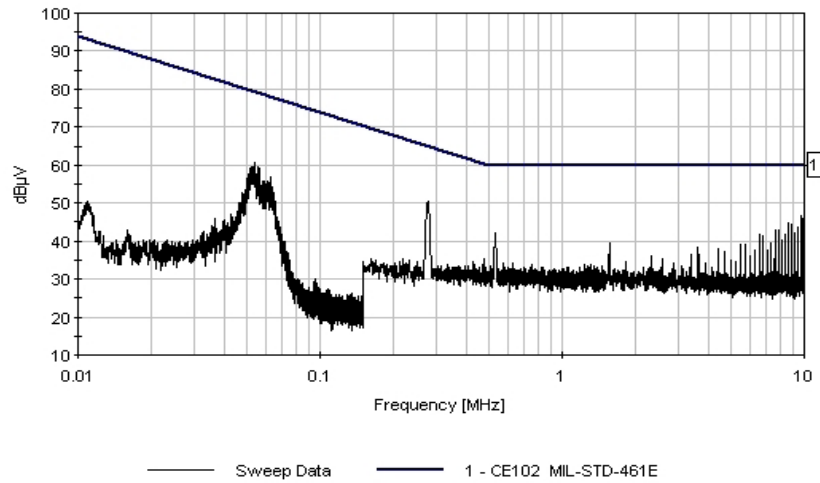

EFIL-28 with 24S15.10HEW, 24VDC Input, Full Load

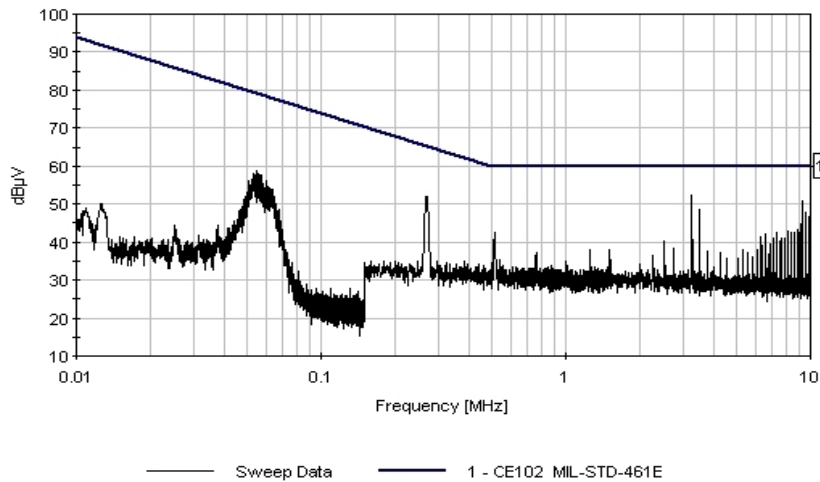

EFIL-28 with 24S24.6HEW, 24VDC Input, Full Load

MIL-STD-461E Conducted Emissions Results CE101, 24VDC Input

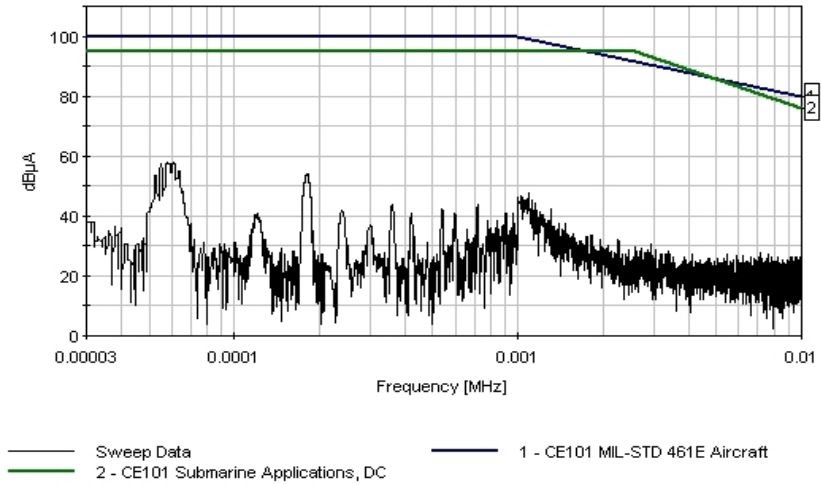

EFIL-28 with 24S3.30HEW, 24VDC Input, Full Load

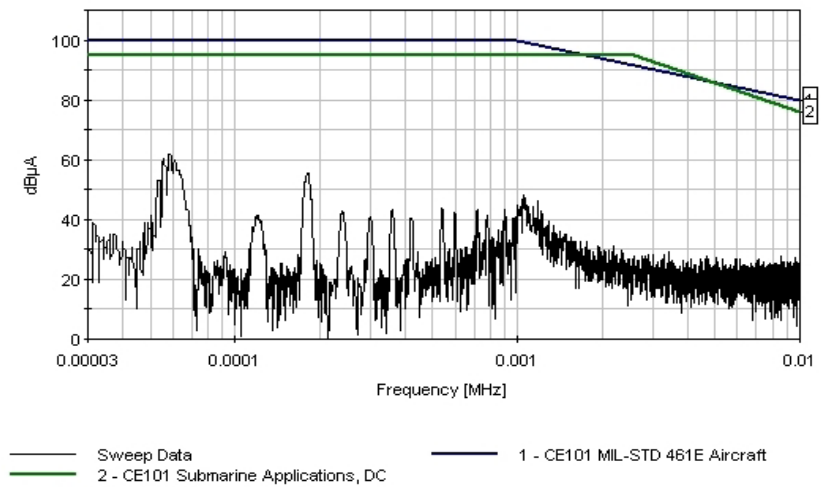

EFIL-28 with 24S5.30HEW, 24VDC Input, Full Load

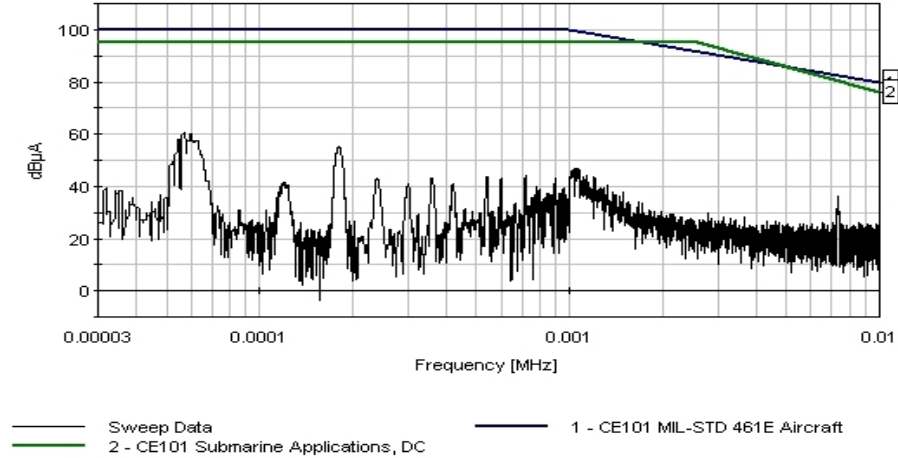

EFIL-28 with 24S12.12HEW, 24VDC Input, Full Load

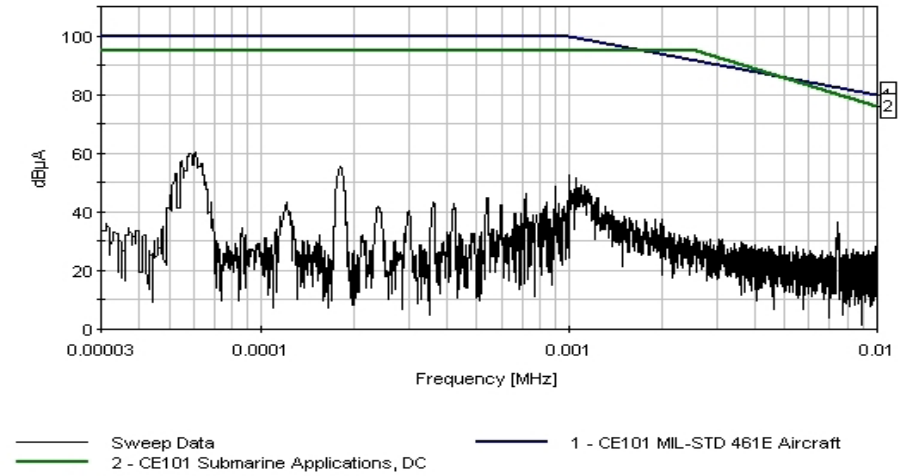

EFIL-28 with 24S15.10HEW, 24VDC Input, Full Load

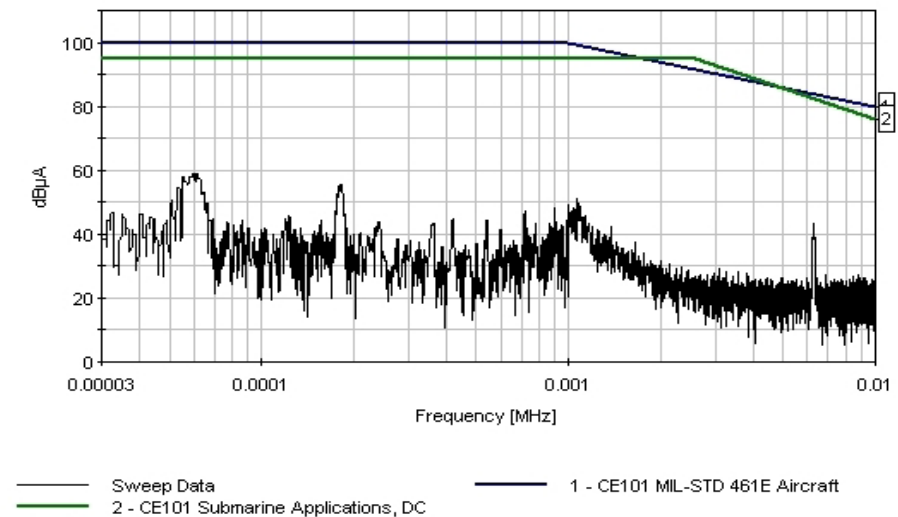

EFIL-28 with 24S24.6HEW, 24VDC Input, Full Load